

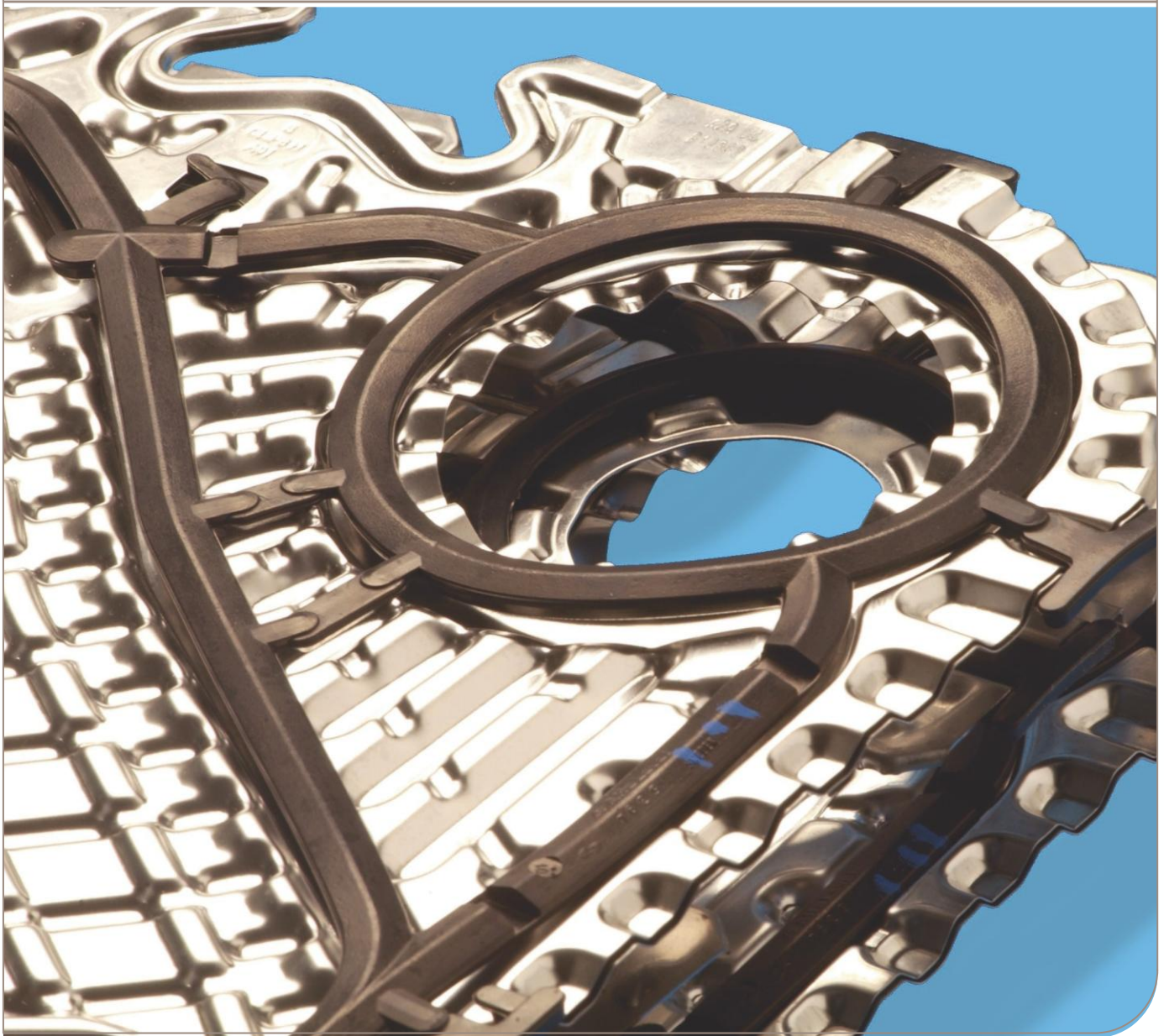

30 Juniper Court.
Covington, GA 30016
770/786-5555
www.mahans.com

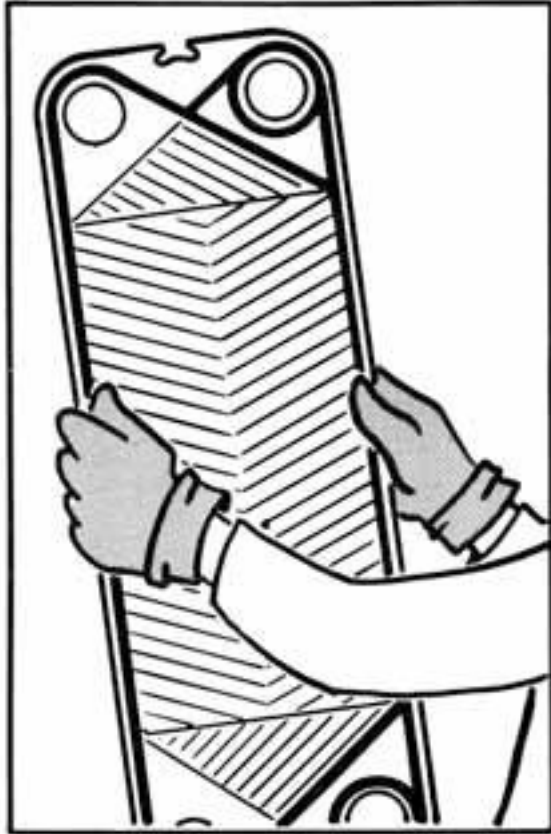

Plate Heat Exchanger Operational and Maintenance Manual





NOTICE



TO AVOID HAND INJURIES,
PROTECTIVE GLOVES
SHOULD ALWAYS BE WORN
WHEN HANDLING PLATES.

PROTECTIVE SHROUDS

IT IS THE RESPONSIBILITY OF EACH PERSON OPERATING OR REPAIRING EQUIPMENT TO TAKE THE NECESSARY PRECAUTIONS TO COMPLY WITH ALL APPLICABLE SAFETY REGULATIONS.

ALFA LAVAL PROVIDES PROTECTIVE SHROUDS FOR ALL OUR PLATE HEAT EXCHANGERS. THESE SHROUDS WILL PREVENT POSSIBLE INJURIES AND/OR DAMAGE AS A RESULT OF SUDDEN LEAKAGE FROM THE PLATE PACKAGE.

List of contents

	CHAPTER
TO OUR VALUED CUSTOMER	1
• Alfa Laval Locations	1.1
THE NAME PLATE - AND THE IDENTIFICATION OF THE EQUIPMENT	2
• Code Plate & Identification Number Locations	2.1, 2.2
GENERAL	3
• Storage	3.1, 3.2
• Lifting	3.3
• Foundation	3.4
• Installation	3.5
• Special Loose Flange Connections	3.6
THE MAIN COMPONENTS AND THEIR FUNCTIONS FOR PARALLEL FLOW UNITS	4A
• List of Parallel Flow Units	4A.1
• Function	4A.2
• How It Works	4A.3
• Heat Transfer	4A.4
• Pressure Drop	4A.4
• Plates	4A.5
• Gaskets	4A.6, 4A.7, 4A.8
THE MAIN COMPONENTS AND THEIR FUNCTIONS FOR DIAGONAL FLOW UNITS	4B
• List of Diagonal Flow Units	4B.1
• Function	4B.2
• How It Works	4B.3
• Heat Transfer	4B.4
• Pressure Drop	4B.4
• Plates	4B.5, 4B.6
• Gaskets	4B.7, 4B.8, 4B.9, 4B.10

List of contents

	CHAPTER
OPERATION	5
• Starting Up	5.1, 5.2
• Unit in Operation	5.3
• Shut Down	5.3
• The Risks of Not Complying With The Start-Up and Shut-Down Procedures	5.4
OPENING AND CLOSING OF THE PLATE PACKAGE	6
• Opening	6.1, 6.2, 6.3, 6.4, 6.5
• Removal and Insertion of plates	6.6
• Closing	6.7, 6.8, 6.9, 6.10, 6.11
MAINTENANCE	7
• Cleaning	7.1, 7.2, 7.3, 7.4, 7.5
• Regasketing	7.6, 7.7, 7.8, 7.9
• End Plate II Gaskets For Parallel Flow Units	7.10
• End Plate II Gaskets For Diagonal Flow Units	7.11
FAULT DETECTION	8
• Leakage at Connections or Plates	8.1, 8.2
• Internal Mixing of Media	8.3
• Pressure Drop Problems	8.4
• Heat Transfer Problems	8.5
SUPPLEMENTARY PARTS	9
• Partition Plate	9.1
• Instrument Ring	9.2

To our valued customer:

Thank you for purchasing an Alfa Laval Plate Heat Exchanger. As the world's largest manufacturer of Heat Exchangers, we are very proud of our products and services. We value you as our customer and wish to assure your satisfaction. We have prepared this Instruction Manual to assist you with your Alfa Laval Plate Heat Exchanger in various situations. We suggest that you look through it carefully, and, above all, make it readily available to any personnel who may need it for reference.

2

The name plate - and the identification of the equipment

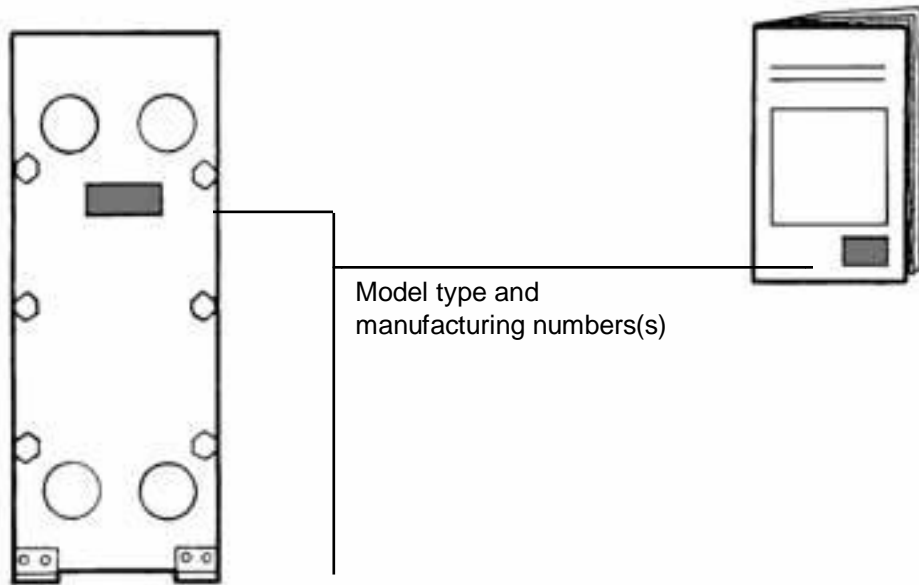

A name plate like the one shown below is fixed to the apparatus as shown above and it gives the following information

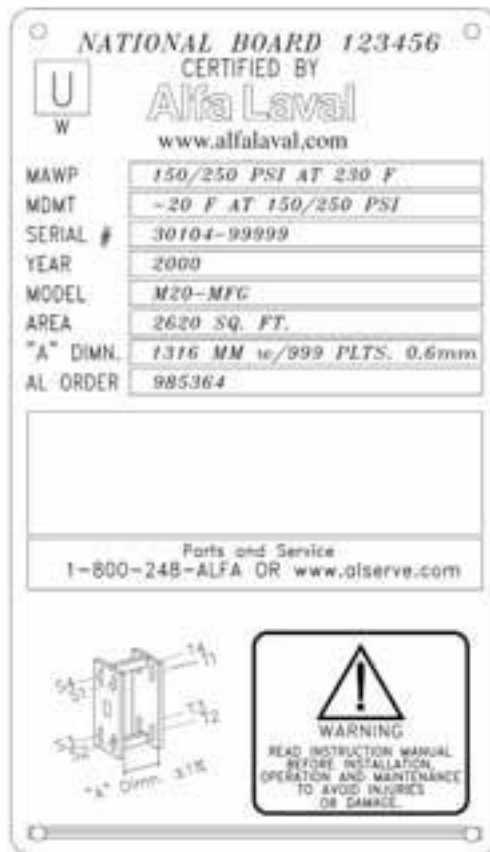

2.1

The name plate - and the identification of the equipment



This instruction manual has been issued for many different models of Alfa Laval *industrial* PHEs. There are separate manuals for *industrial, sanitary, spiral, alfa rex, brazed & evaporator/condensor* heat exchangers.

- WHENEVER USING THE MANUAL, CHECK FIRST THAT THE SERIAL NUMBER ON THE FRONT COVER IS IDENTICAL TO THAT ON THE NAME PLATE OF THE EQUIPMENT.
- IN ALL CORRESPONDENCE WITH ALFA LAVAL, PLEASE REFER TO THE MANUFACTURING SERIAL NUMBER, FOR TRUE IDENTIFICATION OF THE EQUIPMENT.
- WHENEVER CONTACTING ALFA LAVAL ABOUT A PART FOR YOUR PLATE HEAT EXCHANGER, BE SURE TO STATE THE MANUFACTURING SERIAL NO.(S), AND MODEL TYPE.

3

General

STORAGE

In this section, names of heat exchanger parts are mentioned for the first time. For your information, see Chapters 4A or 4B FUNCTION.

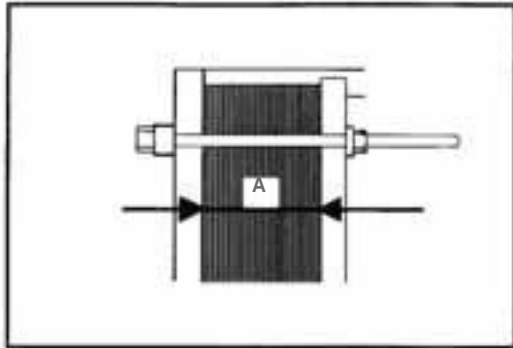

1. Unless otherwise agreed, ALFA LAVAL delivers the plate heat exchanger ready to be put in service upon arrival. This means that the plate package is tightened to its correct measurement A.

Should it be necessary, however, to store the equipment for a longer period (1 month or more) before, certain precautions should be made in order to prevent unnecessary wear of the equipment:

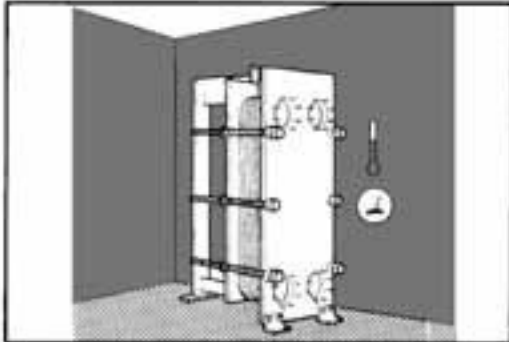

2. Preferably, the heat exchanger should be stored inside, in a room with a temperature around 15 to 20 degrees Celsius (60 to 70 degrees Fahrenheit) and humidity around 70%

There should ABSOLUTELY NOT be any OZONE-PRODUCING equipment in the room, like electric motors or arc-welding equipment, since ozone destroys many rubber materials (cracking).

Do not store organic solvents or acids in the room.

Avoid heat or ultraviolet radiation.

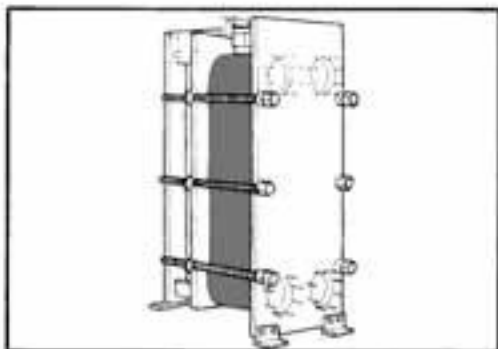

3. Wrapping the PHE with a non-transparent plastic film is a good precaution. Use of transparent film can alter paint color if unit is stored in direct sunlight.

STORAGE

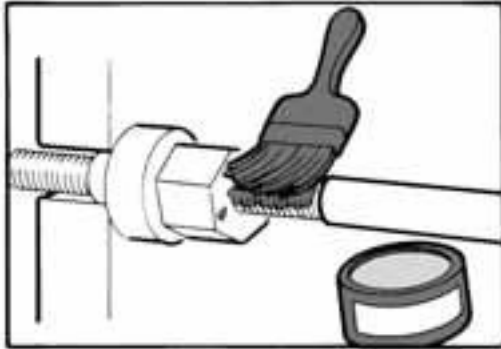

4. The tightening bolts should be well covered with good rust preventing coating, suitable types (LUBRIPLATE FGL-2 or Equivalent) and if not connected to the pipe system, the connections should be covered.

If the heat exchanger must be stored outdoors, the precautions mentioned above should be taken as far as practical. The need for protection against the climate etc. is of course even more important in this case.

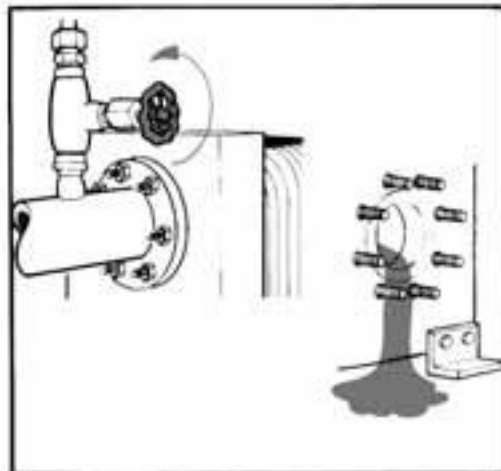

5. If for any reason the heat exchanger is removed from service for a long period, it is advantageous to follow the advice above, even if the equipment is not moved from the location.

The heat exchanger should be VENTED AND DRAINED, and depending on the media processed, it is recommended to RINSE AND DRY it, before it is stored.

LIFTING

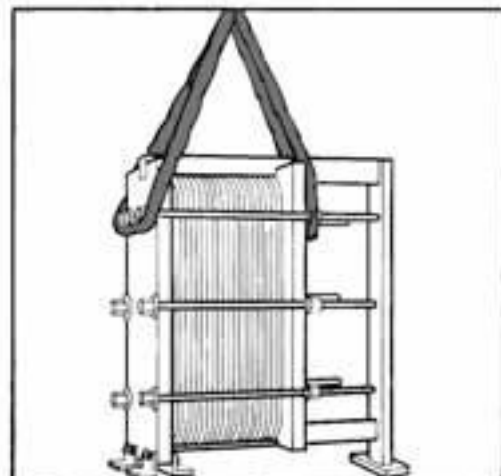

1. Whenever the heat exchanger is lifted, straps should be placed around tightening bolts on both sides of the unit, as shown in picture. If lifting lugs or lifting eyes are provided, always use chains or lifting cables rated above the published weight of the heat exchanger.

NEVER LIFT BY THE CONNECTIONS OR THE STUDS AROUND THEM!

3

General

LIFTING CONTINUED

If Lifting Lugs are provided

If you are to lift the heat exchanger itself, straps should be used. They should be placed as shown on the picture.

On smaller units (4" connected size smaller) typically two lifting lugs are required instead of four.

WARNING!

Never lift by the connections or the studs around them.

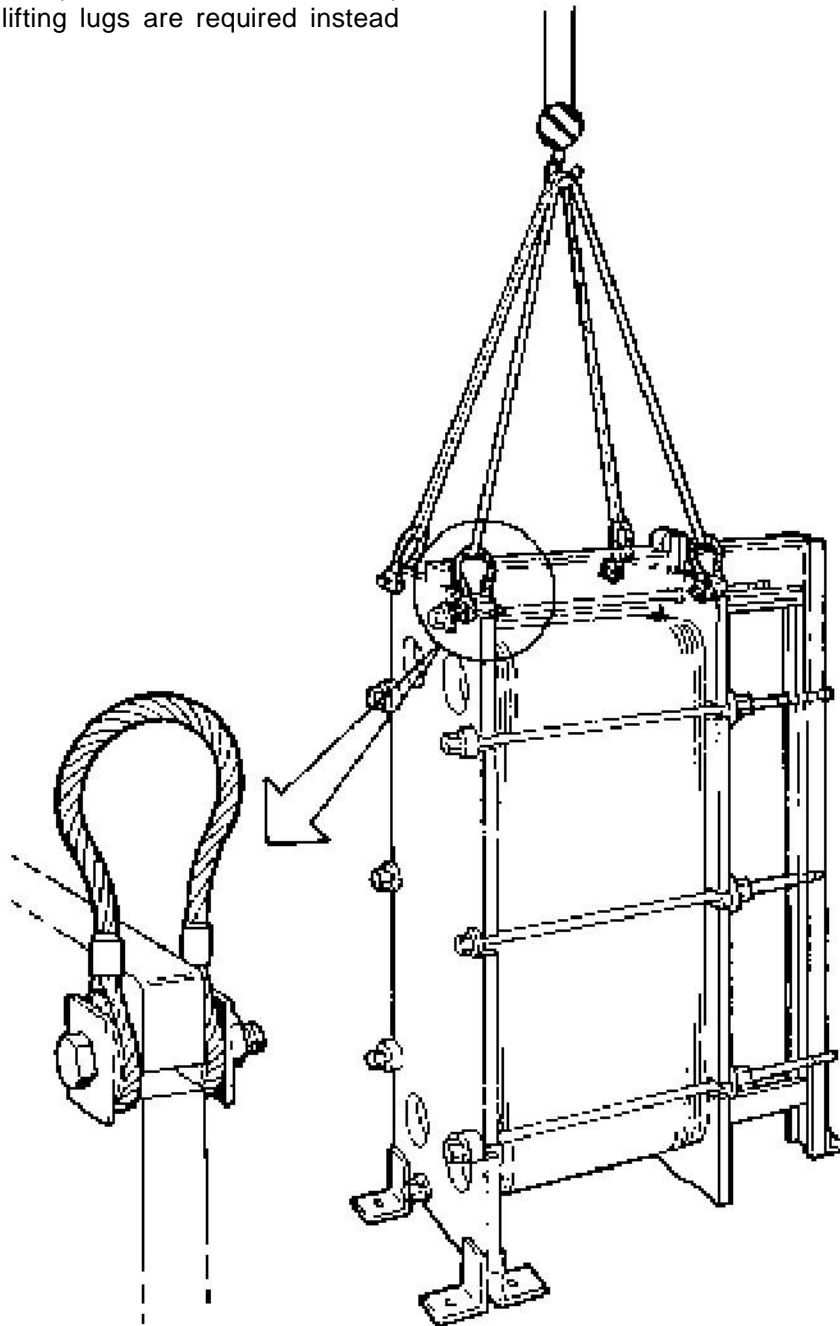

General

FOUNDATIONS.

All information necessary for the preparation of the foundation appears on the data sheet provided by ALFA LAVAL.

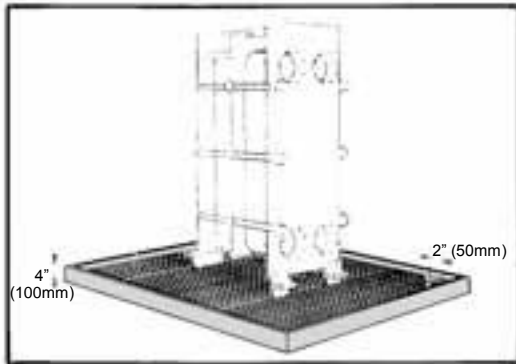

In some cases (installation on board a ship, when processing corrosive liquids, etc.) it may be practical to place the heat exchanger in a DRAINAGE BOX (with capacity for the total volume of the heat exchanger). The outlet of the drainage box should be generously dimensioned, not less than (2") 50 mm diameter.

INSTALLATION.

BEFORE connecting any piping to the heat exchanger, **MAKE SURE THAT ALL FOREIGN OBJECTS HAVE BEEN FLUSHED OUT OF THE SYSTEM!**

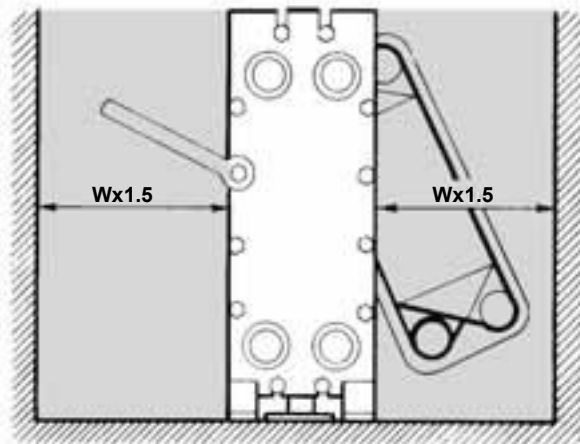

PLEASE OBSERVE THAT

The measurements given in the picture above are recommended by ALFA LAVAL, it is necessary to leave free space around the equipment, to provide access and make future service possible. Except for a place to put the plates, if removed from the heat exchanger, **NO FURTHER SPACE** is required for servicing the PHE.

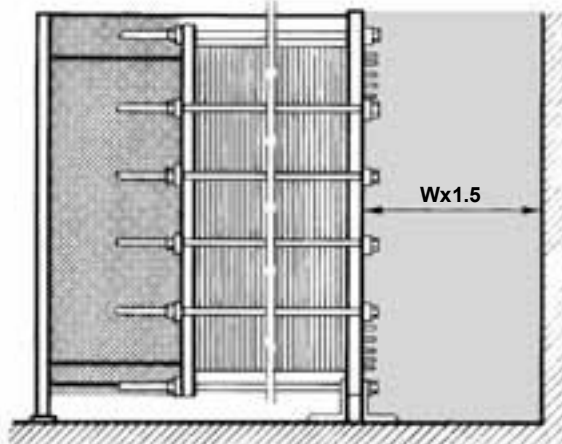

PLEASE OBSERVE THAT

The measurements given in the picture are recommended by ALFA LAVAL, to provide reasonably good working conditions during installation of the heat exchanger as well as for future maintenance and service. If floor space is restricted, the dimensions suggested can be reduced. It is left to the purchaser to decide just how much access space is required.

 This field should be kept free from fixed installations.

 Recommended free space for opening and closing.

3

General

PIPES

Always ensure that no measurable stress is placed on the heat exchanger by the piping system.

SHUT OFF VALVES

To enable the heat exchanger to be opened when necessary shut off valves should be provided on all connections.

PRESSURE RELIEF DEVICES

It is the responsibility of the user to ensure that the required pressure relief devices are properly installed prior to initial operation. Refer to the applicable Code(s) and corresponding Standard(s) for proper size requirements of these pressure relief devices.

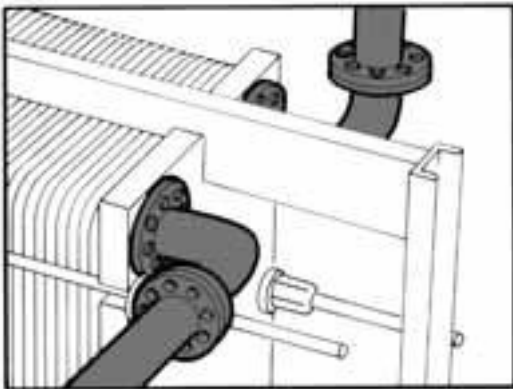

CONNECTIONS ON THE PRESSURE PLATE (REAR COVER)

Some plate heat exchangers may also have connections on the pressure plate. In such cases, it is important to check against the drawing or the name plate that the plate pack has been tightened to the right measurement before the piping is connected.

Whenever piping is connected to the pressure plate, a short 90° spool piece shall be installed between the heat exchanger and the piping. These should be directed upwards or sideways. This simplifies pressure plate removal during servicing.

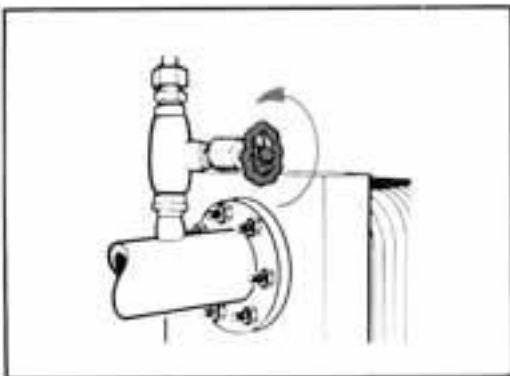

Venting of both sides of the heat exchanger must be provided. This is important and enables air to be drawn from the system during start-up. It also enables air or gas to be removed during operation, and it enables faster drainage.

Special Loose Flange Connections

Loose Flanges are provided on certain model types due to interference. When provided these flanges shall be incorporated into the piping.

MODELS WITH BOTH "S" AND "T" PORT CONNECTIONS

M6-FD, M6-MFD, M6-MWFD, M10-BFD, M10-MFD, M10-BWFD, M10-BDFD, M20-MFD*, M20-MWFD*

MODEL TYPES WITH LOOSE FLANGE ON T PORT CONNECTIONS ONLY:

M6-FG, M6-MFG, M6-MWFG, M10-BFG, M10-MFG, M10-BWFG, M10-BDFG, V28-FD*, V45-FD*, M20-MFG, M20-MWFG

* Loose flange only when design pressures above 230 psi.

Notes:

- 1) Sports connections on these model types utilized industry standard flanges.
- 2) Not all exchangers require T port connections.

PIPING CONNECTION

The loose flange is connected to piping by use of a commercially available stub end of same material as the piping.

The stub end is installed as shown and then butt weld to the piping.

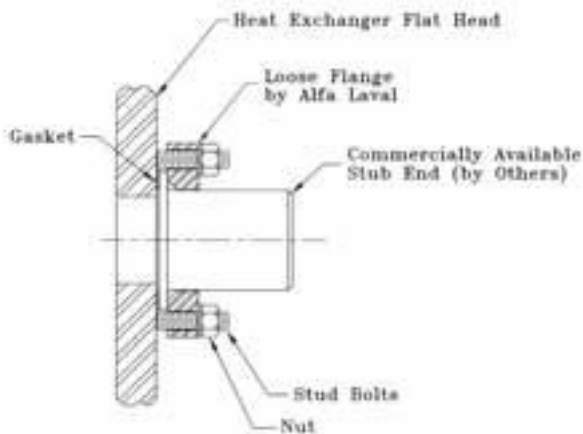

4A

LIST OF PARALLEL FLOW UNITS

“A” SERIES UNITS:

AM10-FG; AM10-FS

A15-BFL; A15-BFG; A15-BFD; A15-BWFG; A15-BWFD

A20-BFL; A20-BFG; A20-BFD

AM20-FG; AM20-BFG; AM20-WFG; AM20-SFG; AM20-DWFG

AK20-FG; AK20-FD; T200-FG; T200-FD

AX30-BFG; AX30-BFD; AX30-BWFG; AX30-BWFD

A35-HA

“M” SERIES UNITS:

M3-VG

M6-FG; M6-FD; M6-MFG; M6-MFD; M6-MWFD/FG/FDR/FGR

M10-BFM; M10-BFG; M10-BFD; M10-MFG; M10-MFD;

M10-BWFG; M10-BWFD; M10-BWFGR, M10-BWFDR

M15-BFG; M15-BFD; M15-BFS; M15-MFG;

M15-MFD; M15-MFS; MK15-BWFD; MK15-BWFG

M20-MFG; M20-MFM; M20-MFD; M20-MWFG; M20-MWFD

M30-FM; M30-FG; M30-FD

MA30-FD; MA30-FG; MA30-WFG; MA30-WFD

MX25-BFG; MX25-BFD; MX25-BFS

EC500-WTFE; EC500-WTFL

“V” SERIES UNITS:

V8-VG, V13-FG, V13-FD, V20-FG, V20-FD

PARALLEL FLOW UNITS

4A

Function

THE MAIN COMPONENTS OF THE PLATE HEAT EXCHANGER AND THEIR FUNCTIONS.

In ALFA LAVAL Plate Heat Exchangers, heat is transferred from one medium to another through thin metal plates which have been pressed into a special pattern.

1. FRAME PLATE

2. SUPPORT COLUMN

The two bars are suspended between the FRAME PLATE, to which in most cases the piping is connected, and a SUPPORT COLUMN.

4. CARRYING BAR

5. GUIDING BAR

The plates hang from a CARRYING BAR at the top and are kept in line by a GUIDING BAR at the bottom.

7. PRESSURE PLATE

The pressure plate is hung on the carrying bar and is moveable, as are the heat transfer plates. In some cases piping may be connected to the pressure plate.

3. CONNECTIONS

Holes matching the piping lead through the frame plate, permitting the media to enter into the heat exchanger. Threaded studs around the holes secure the pipes to the equipment. Depending on the application, metallic or rubber-type LININGS may protect the edges of the holes against corrosion.

6. TIGHTENING BOLTS

With the package of thin plates hanging between the frame plate and the pressure plate, a number of TIGHTENING BOLTS are used to press the thin plates together, bringing them into metallic contact, and to compress the gaskets, enough to seal off the narrow passages which have now been formed between the plates.

8. CHANNEL PLATES

9. GASKET

These plates are called CHANNEL PLATES. A groove along the rim of the plate and around the ports hold a GASKET, usually made of a rubber-type material.

Heat is transferred through the surface which is contained by the gasket, except for some small areas near the corners.

The number of plates in your heat exchanger is determined by the size of the heat transfer surface required.

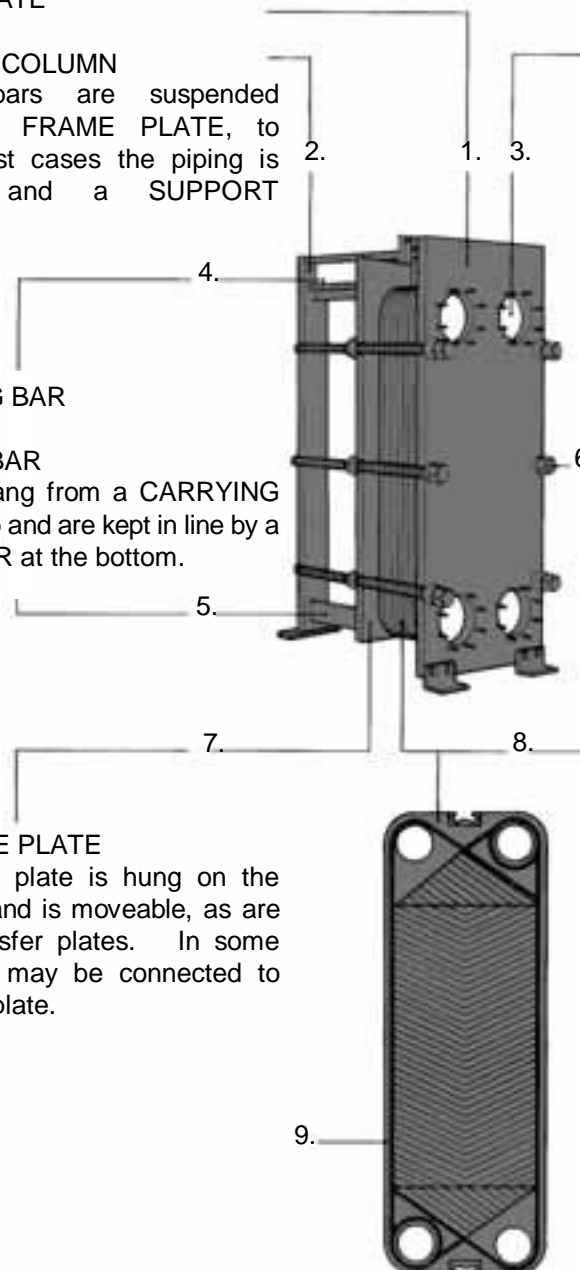

4A

PARALLEL FLOW UNITS

How it works

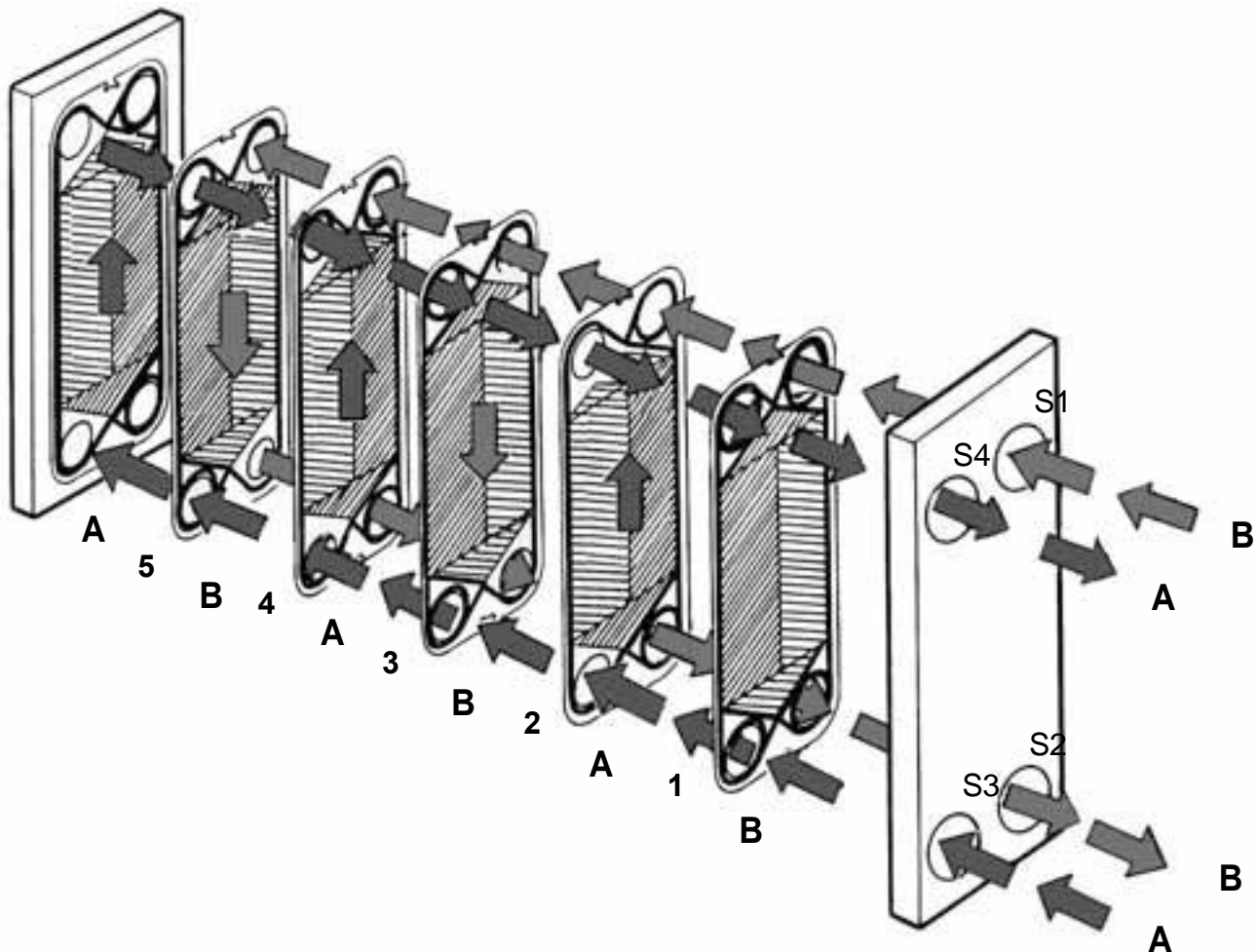

When a package of plates are pressed together, the holes at the corners form continuous tunnels or manifolds, leading the media (which participate in the heat transfer process) from the inlets into the plate pack, where they are distributed in the narrow passages between the plates.

Because of the gasket arrangement on the plates, and the placing of "A" and "B" plates alternately, the two liquids enter alternate passages, e.g. the warm liquid between even number passages, and cold liquid between odd number passages.

Thus the media are separated by a thin metal wall. In most cases the liquids flow in opposite directions.

During the passage through the equipment, the warmer medium will give some of its heat energy to the thin wall, which instantly loses it again to the colder medium on the other side.

The warmer medium drops in temperature, while the colder one is heated up.

Finally, the media are led into similar hole-tunnels at the other end of the plates and discharged from the heat exchanger.

4A.3

PARALLEL FLOW UNITS

4A

Heat transfer



The purpose of the equipment is to transfer heat from one medium to another. Heat passes very easily through the thin wall separating the two media.

The novel pattern into which the plate material has been formed not only gives strength and rigidity, but greatly increases the rate of heat transfer from the warmer medium to the metal wall and from the wall to the other medium.

This high heat flow through the walls can be seriously reduced by the formation of deposits of various kinds on the wall surfaces.

The pattern of corrugation on Alfa Laval plates mentioned above induces highly turbulent flow. The turbulence gives strong resistance to the formation of deposits on the plate surface; however, it cannot always eliminate fouling.

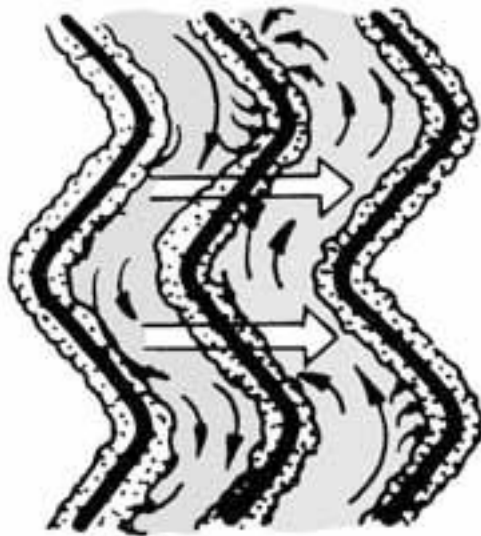

The deposits may increase the total “wall thickness” substantially, and they consist of materials that have a much lower thermal conductivity than the metal plate. Consequently a layer of deposits can severely reduce the overall heat transfer rate.

The deposits will be considered in the chapter on MAINTENANCE and CLEANING. At this point we will only establish that this fouling is unwanted and can under certain circumstances, be harmful to the heat exchanger because corrosion may occur under the deposits.

Pressure drop

Pressure drops are wasted energy.

All pipe systems and equipment included in them offer resistance to media flowing through them.

Some pressure drop is unavoidable, but for a given PHE it should be kept as close as possible to the designed value.

The formation of deposits on the heat transfer surfaces instantly leads to a reduction of the free space between the plates. This means that more energy is needed to get the desired flow through the equipment.

It is clear that the fouling of the surfaces is undesirable.

Larger particles and fibers may also be drawn into the heat exchanger and clog the passage ways if strainers or other means of protection have not been provided for.

A reduced ability by the heat exchanger to hold the desired temperatures, in combination with an increased pressure drop on any of the media, indicates that fouling or clogging is taking place.

For corrective action, see MAINTENANCE and CLEANING.

4A

PARALLEL FLOW UNITS

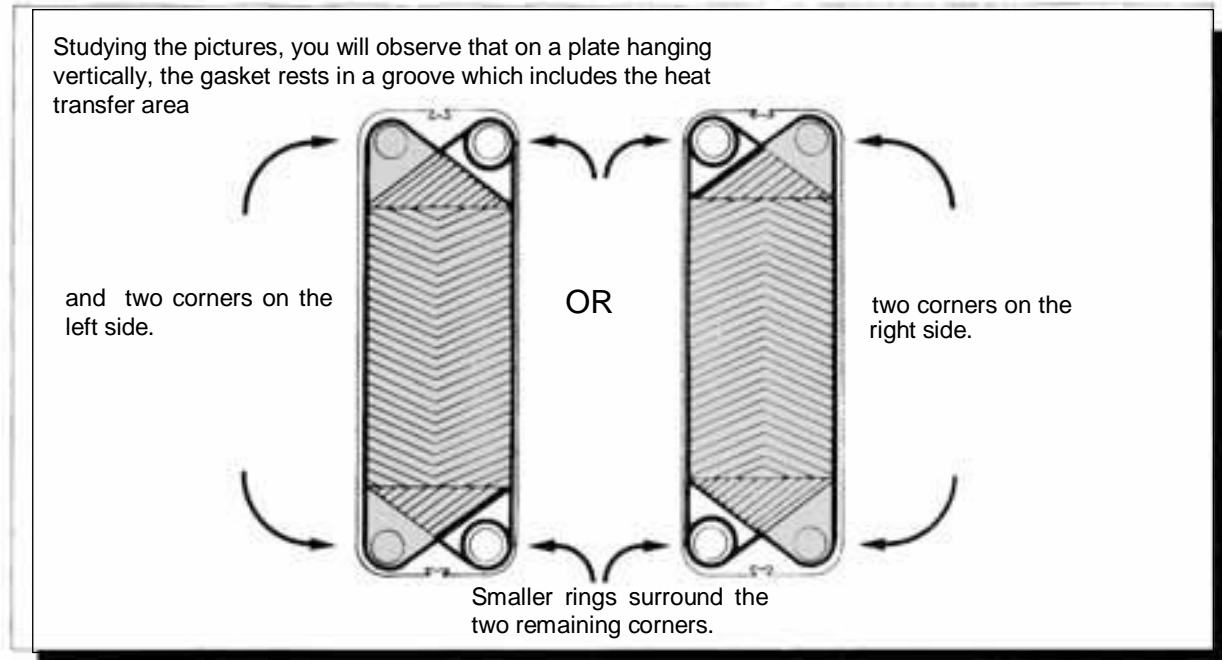

We decide that we will name the plates after these two situations.

An A-plate is a plate hanging with the chevron pointing downwards.

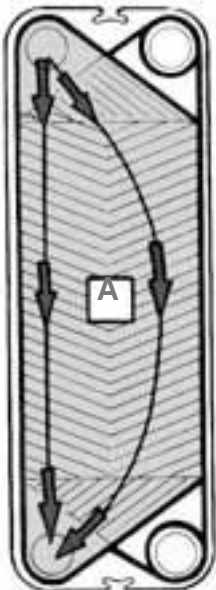

A B-plate is a plate hanging with the chevron pointing upwards.

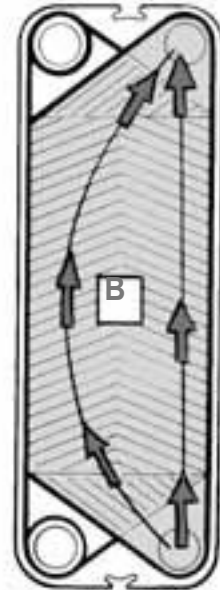
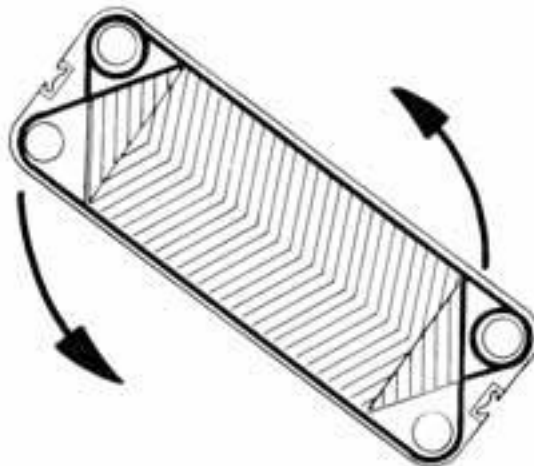

If we turn an A-plate upside down we will have a B-plate:

4A.5

Gaskets

The GASKET is molded in one piece. The material is normally an elastomer, selected to suit the actual combination of temperature, chemical environment and possible other conditions that may be present.

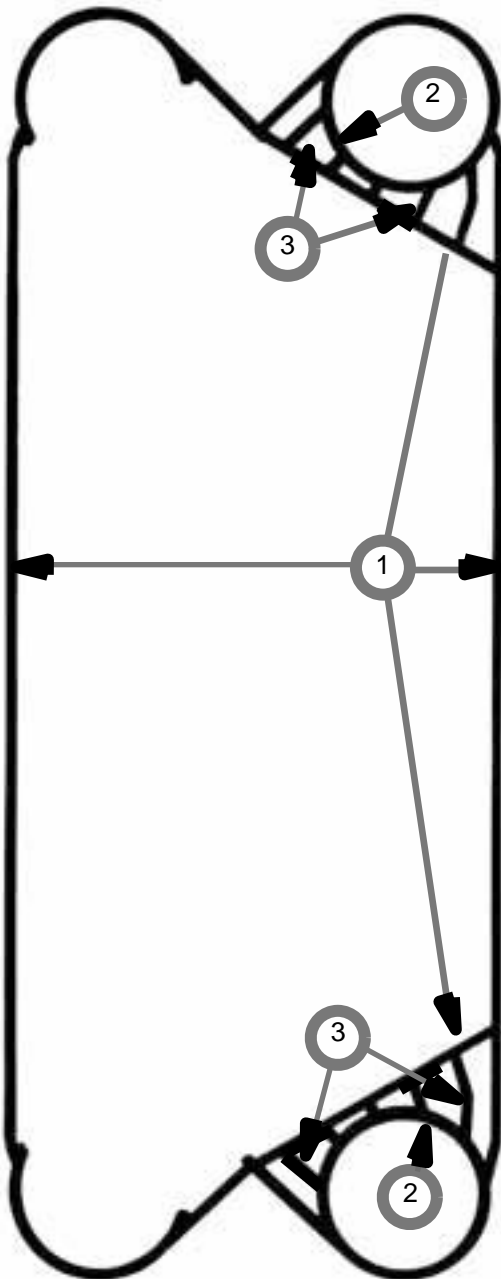

The one-piece gasket consists of:

1. One field gasket
2. Two ring gaskets
3. Links

The field gasket is by far the larger part containing the whole heat transfer area and the two corners connected to it. The ring gaskets seal off the remaining two corners.

These three pieces are held together by a few short links, which have no sealing function at all. Their purpose is simply to tie the pieces together and to add some support in certain areas. On some plate heat exchangers, the gasket is held in place on the plate by means of a suitable cement or glue.

4A

PARALLEL FLOW UNITS

Gaskets

As already demonstrated, the two media are effectively kept apart by the ring and field gaskets. To prevent intermixing of the media in the corner areas where field and ring gaskets are very close to each other, the link pieces have a number of slots which opens the area between the field and ring gaskets to atmosphere. Any leakage of media across either gasket will escape from the heat exchanger through the slots.

It is important that these openings are kept clear. If they are not, there is a risk that should a leak occur in that region of the plate, there might be a local pressure build-up, which could allow one medium to mix with the other.

Care should be taken not to cut or scratch the gaskets while handling plates.

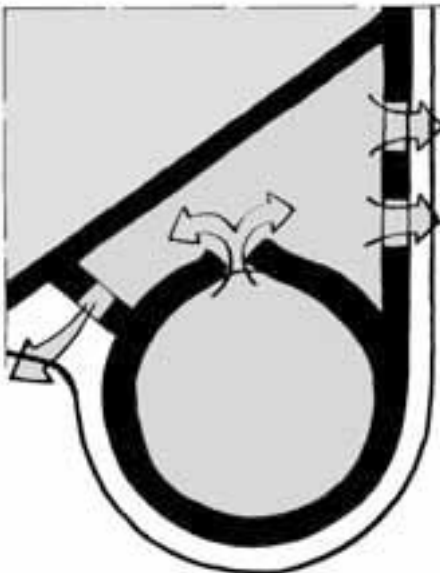
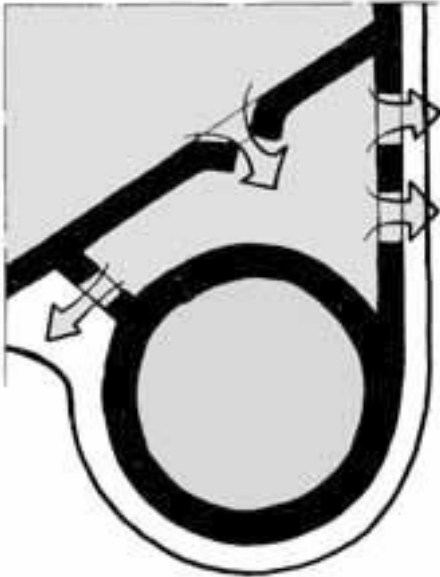

4A

PARALLEL FLOW UNITS

TRANSITION PLATE

M30, MX25, A20-B, AM20, AK20, T200, A15-B, M15, M10, M6

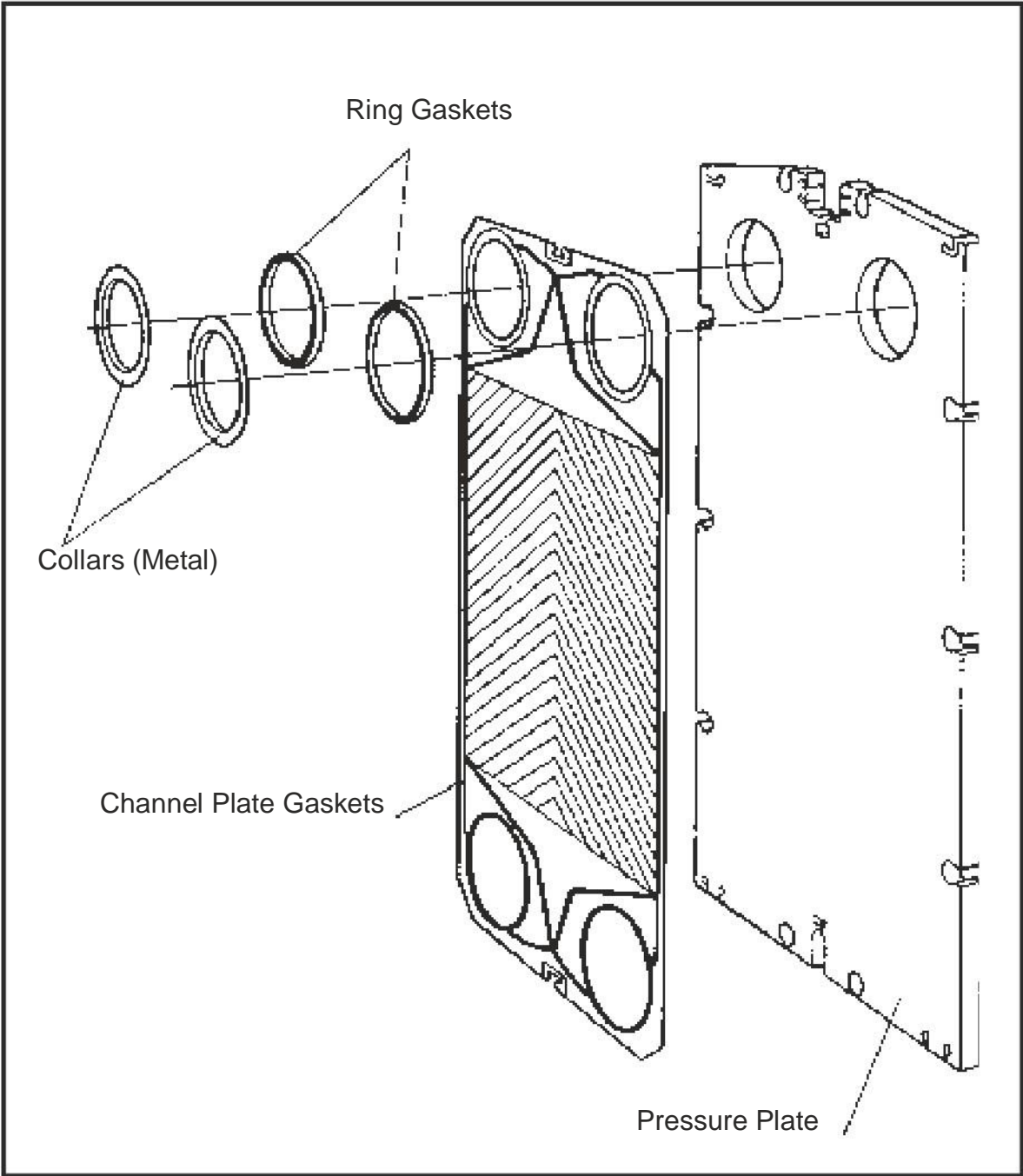

4B List of Diagonal Flow Units

“A” SERIES UNITS:

A10-BFG; A10-BFD

AX35-FG

A45-FG

“P” SERIES UNITS:

P2-FG; P2-VLCH; P2-DWFG

P3-E;P3-EH

“M” SERIES UNITS:

M3-XVG

“V” SERIES UNITS:

V28-FG, V28-FD, V45-FG, V45-FD, V110-FG, V110-FD,
V170-FG, V170-FD, V280-FG, V280-FD

Function

THE MAIN COMPONENTS OF THE PLATE HEAT EXCHANGER AND THEIR FUNCTIONS.

In ALFA LAVAL Plate Heat Exchangers, heat is transferred from one medium to another through thin metal plates which have been pressed into a special pattern.

1. FRAME PLATE

2. SUPPORT COLUMN

The two bars are suspended between the FRAME PLATE, to which in most cases the piping is connected, and a SUPPORT COLUMN.

4. CARRYING BAR

5. GUIDING BAR

The plates hang from a CARRYING BAR at the top and are kept in line by a GUIDING BAR at the bottom.

7. PRESSURE PLATE

The pressure plate is hung on the carrying bar and is moveable, as are the heat transfer plates. In some cases piping may be connected to the pressure plate.

3. CONNECTIONS

Holes matching the piping lead through the frame plate, permitting the media to enter into the heat exchanger. Threaded studs around the holes secure the pipes to the equipment. Depending on the application, metallic or rubber-type LININGS may protect the edges of the holes against corrosion.

6. TIGHTENING BOLTS

With the package of thin plates hanging between the frame plate and the pressure plate, a number of TIGHTENING BOLTS are used to press the thin plates together bringing them into metallic contact, and to compress the gaskets enough to seal off the narrow passages which have now been formed between the plates.

8. CHANNEL PLATES

9. GASKET

These plates are called CHANNEL PLATES. A groove along the rim of the plate and around the ports hold a GASKET, usually made of a rubber-type material.

Heat is transferred through the surface which is contained by the gasket, except for some small areas near the corners.

The number of plates in your heat exchanger is determined by the size of the heat transfer surface required.

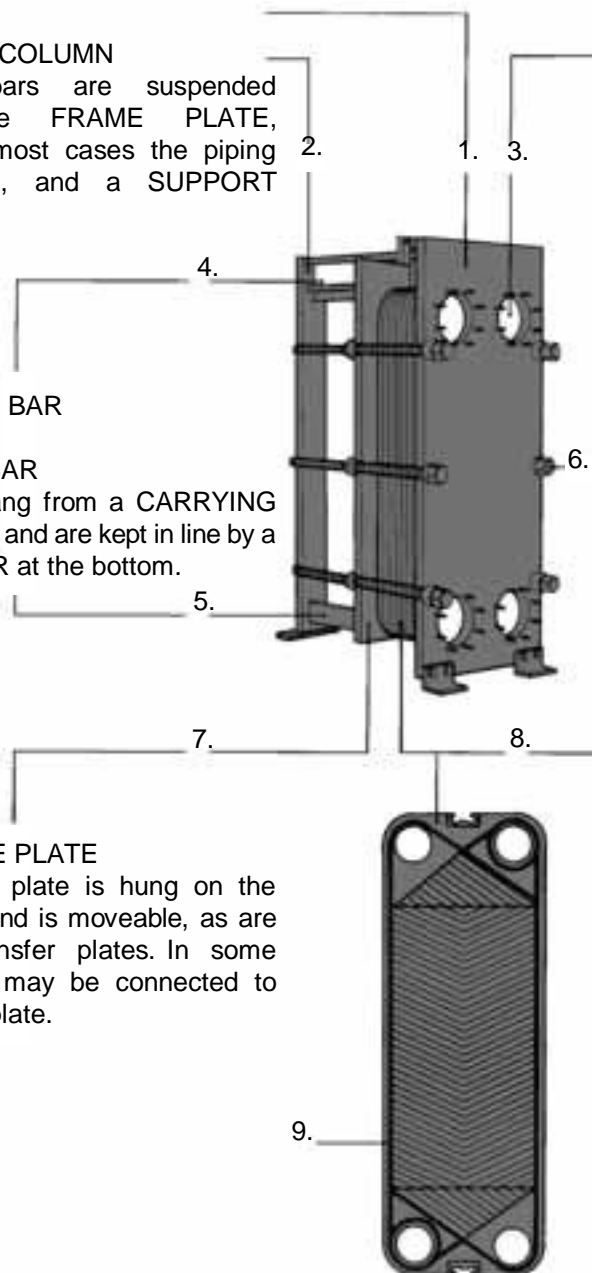

4B

DIAGONAL FLOW UNITS

How it works

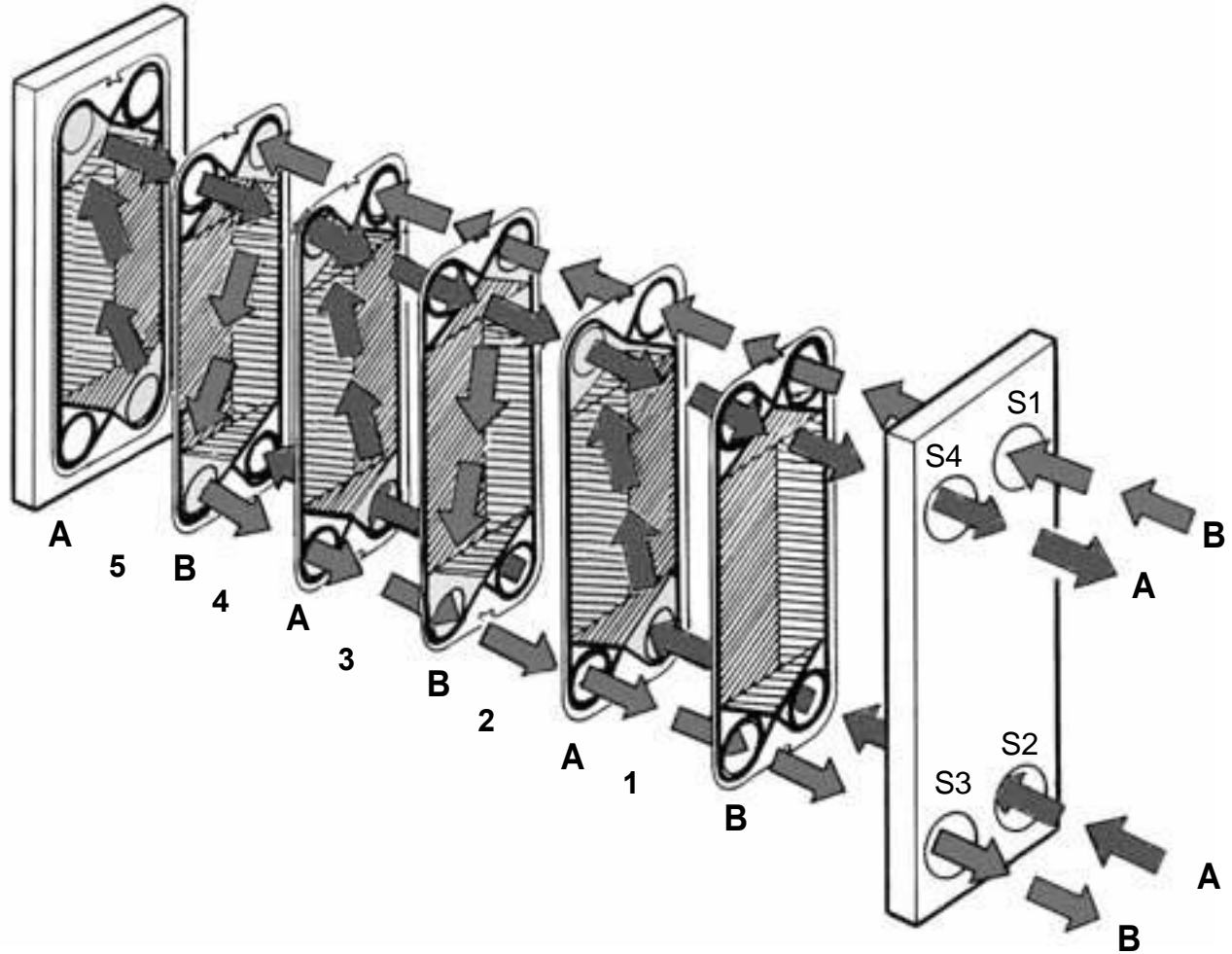

When a package of plates are pressed together, the holes at the corners form continuous tunnels or manifolds, leading the media (which participate in the heat transfer process) from the inlets into the plate pack, where they are distributed in the narrow passages between the plates.

Because of the gasket arrangement on the plates, and the placing of "A" and "B" plates alternately, the two liquids enter alternate passages, e.g. the warm liquid between even number passages, and cold liquid between odd number passages.

Thus the media are separated by a thin metal wall. In most cases the liquids flow in opposite directions.

During the passage through the PHE, the warmer medium will give some of its heat energy to the thin wall, which instantly loses it again to the colder medium on the other side.

The warmer medium drops in temperature, while the colder one is heated up.

Finally, the media are led into similar hole-tunnels at the other end of the plates and discharged from the heat exchanger.

4B.3

Heat transfer



The purpose of the equipment is to transfer heat from one medium to another, and heat passes very easily through the thin wall separating the two media.

The novel pattern into which the plate material has been formed not only gives strength and rigidity, but greatly increases the rate of heat transfer from the warmer medium to the metal wall and from the wall to the other medium.

This high heat flow through the walls can be seriously reduced by the formation of deposits of various kinds on the wall surfaces.

The pattern of corrugation on Alfa Laval plates mentioned above induces highly turbulent flow. The turbulence gives strong resistance to the formation of deposits on the plate surface; however, it cannot always eliminate fouling.

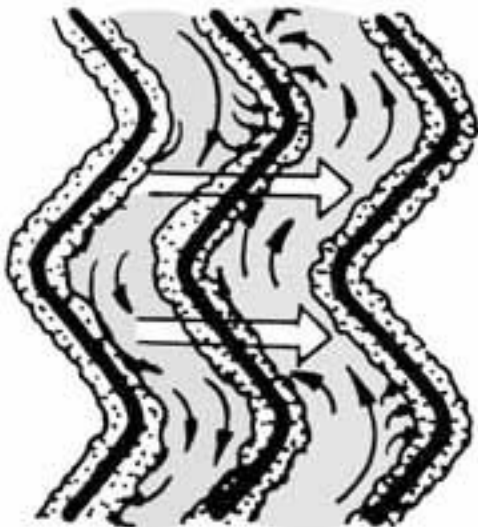

The deposits may increase the total “wall thickness” substantially, and they consist of materials that have a much lower thermal conductivity than the metal plate. Consequently a layer of deposits can severely reduce the overall heat transfer rate.

The deposits will be considered in the chapter on MAINTENANCE and CLEANING. At this point we will only establish that this fouling is unwanted and can under certain circumstances, be harmful to the heat exchanger because corrosion may occur under the deposits.

Pressure drop

Pressure drops are wasted energy.

All pipe systems and equipment included in them offer resistance to media flowing through them.

Some pressure drop is unavoidable, but for a given PHE it should be kept as close as possible to the designed value.

The formation of deposits on the heat transfer surfaces instantly leads to a reduction of the free space between the plates. This means that more energy is needed to get the desired flow through the equipment.

It is clear that the fouling of the surfaces is undesirable.

Larger particles and fibers may also be drawn into the heat exchanger and clog the passage ways if strainers or other means of protection have not been provided for.

A reduced ability by the heat exchanger to hold the desired temperatures, in combination with an increased pressure drop on any of the media, indicates that fouling or clogging is taking place.

For corrective action, see MAINTENANCE and CLEANING.

4B

DIAGONAL FLOW UNITS

Plates

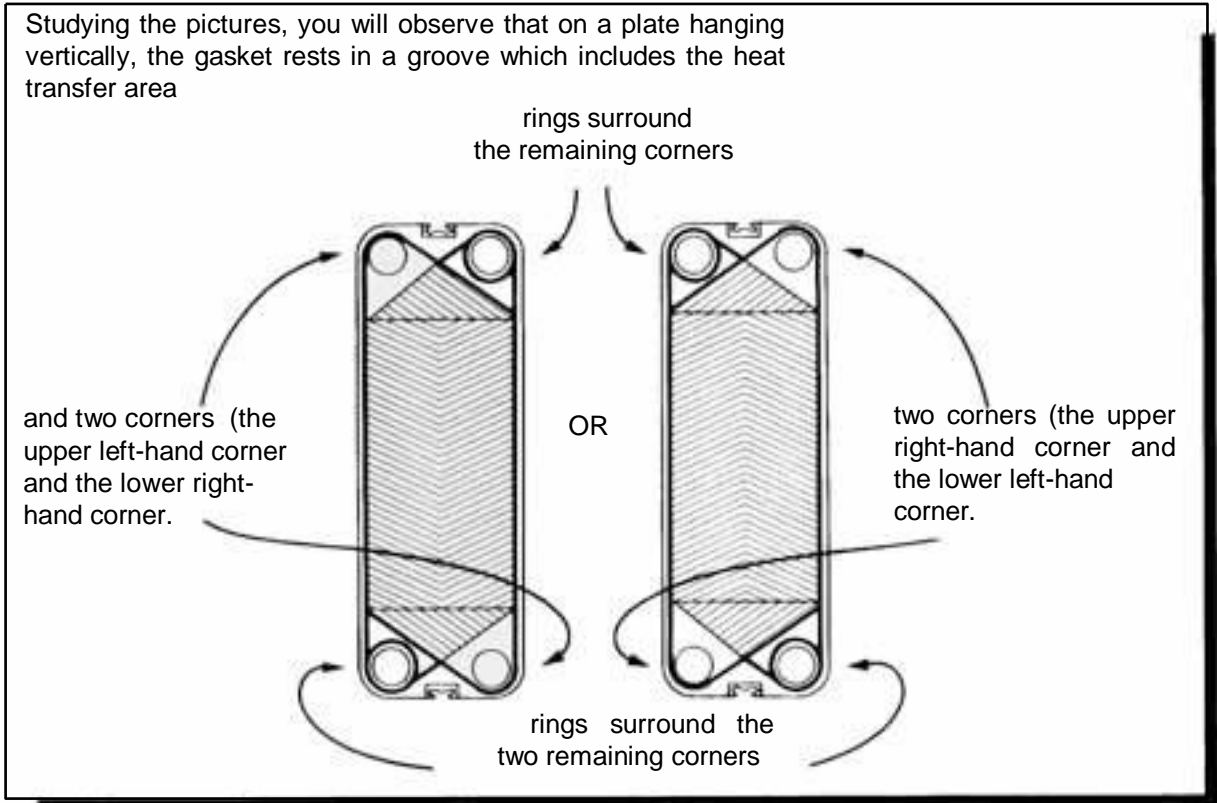

Depending on which two corners are included with the heat transfer area, the plate is called an A- or a B-Plate.

An A-plate is a plate hanging with the chevron pointing downwards.

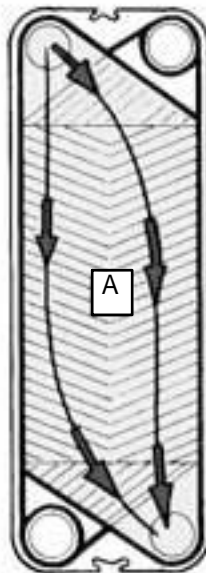

A B-plate is a plate hanging with the chevron pointing upwards.

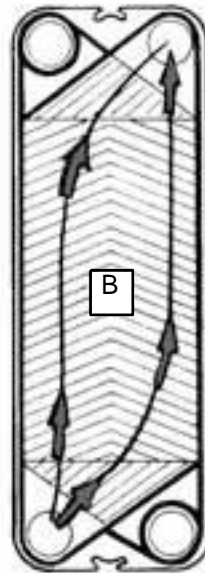

DIAGONAL FLOW UNITS

4B

Plates

We can make a B-Plate from an A-plate or the opposite, by changing the gasket and turning the plate upside down.

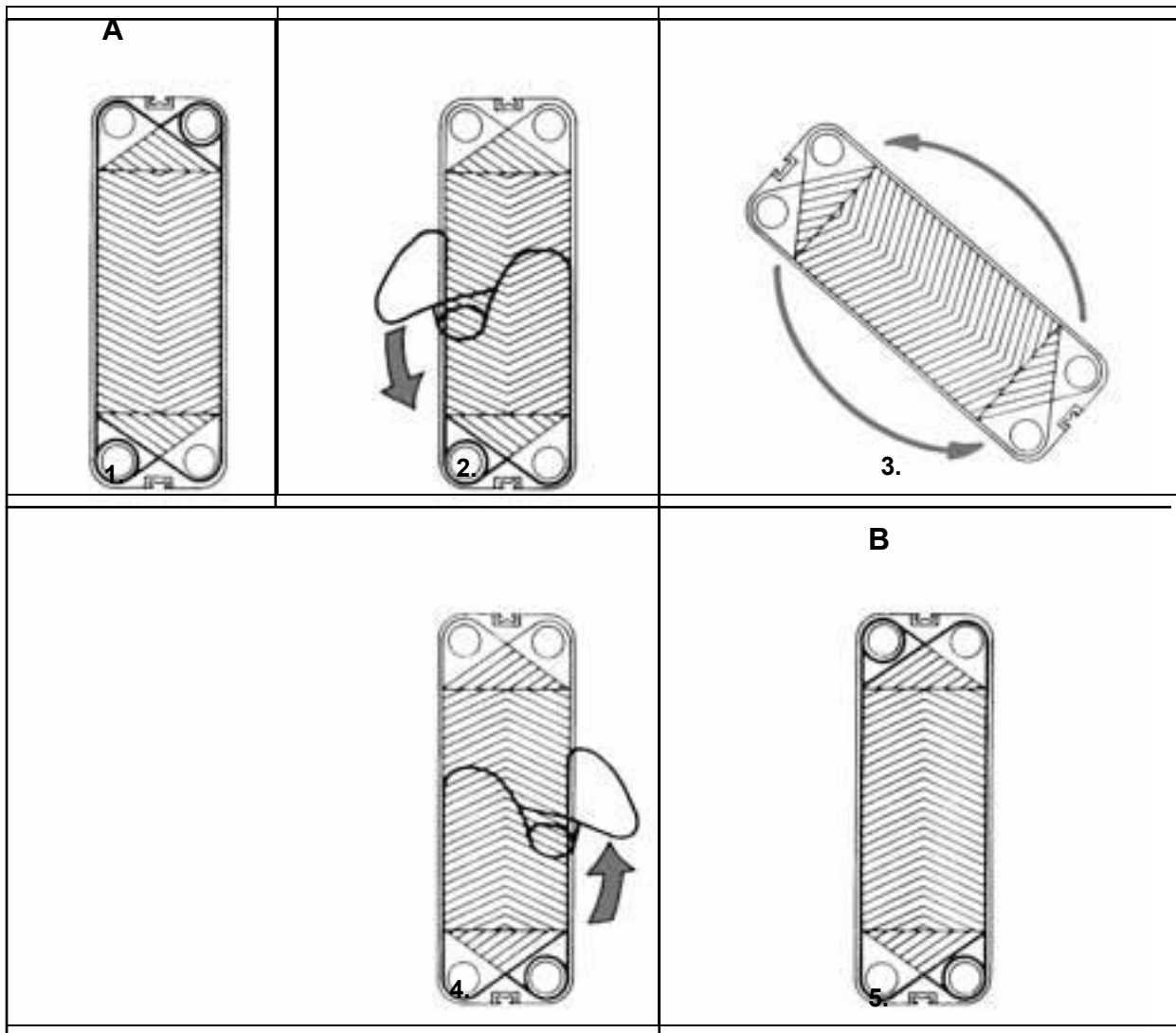

4B

DIAGONAL FLOW UNITS

Gaskets

The GASKET is molded in one piece. The material is normally an elastomer, selected to suit the actual combination of temperature, chemical environment and possible other conditions that may be present.

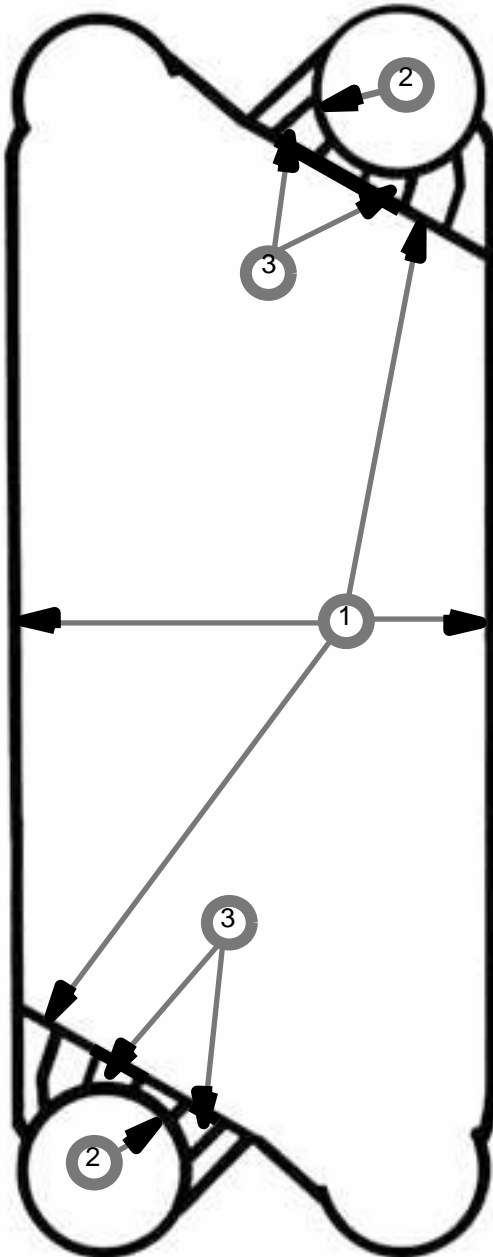

The one-piece gasket consists of:

1. One field gasket
2. Two ring gaskets
3. Links

The field gasket is by far the larger part containing the whole heat transfer area and the two corners connected to it. The ring gaskets seal off the remaining two corners.

These three pieces are held together by a few short links, which have no sealing function at all. Their purpose is simply to tie the pieces together and to add some support in certain areas. On some plate heat exchangers, the gasket is held in place on the plate by means of a suitable cement or glue.

Gaskets

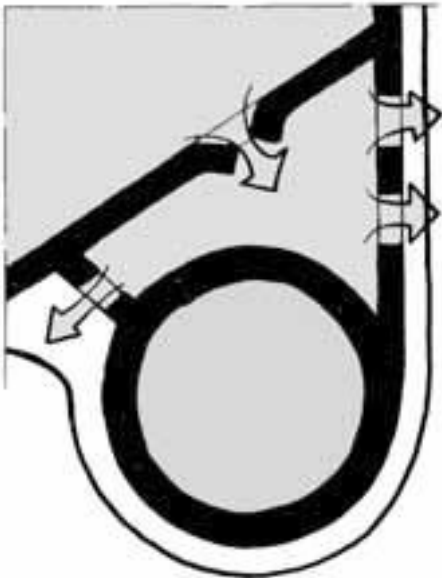

As already demonstrated, the two media are effectively kept apart by the ring and field gaskets. To prevent intermixing of the media in the corner areas where field and ring gaskets are very close to each other, the link pieces have a number of slots which open the area between the field and ring gaskets to atmosphere. Any leakage of media across either gasket will escape from the heat exchanger through these slots.

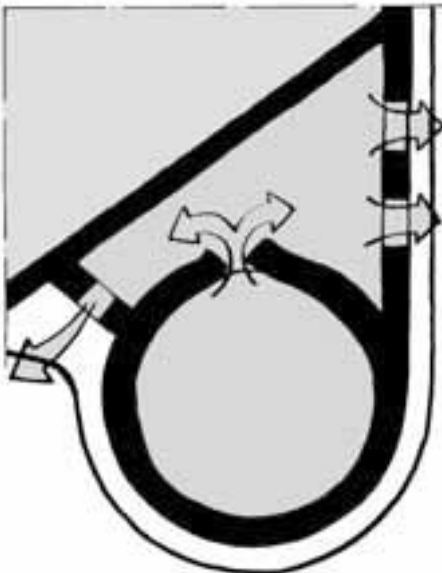

It is important that these openings are kept clear. If they are not, there is a risk that should a leak occur in that region of the plate, there might be a local pressure build-up, which could allow one medium to mix with the other.

Care should be taken not to cut or scratch the gaskets while handling plates.

4B

DIAGONAL FLOW UNITS

TRANSITION PLATE

M30, MX25, A20-B, AM20, AK20, T200, A15-B, M15, M10, M6

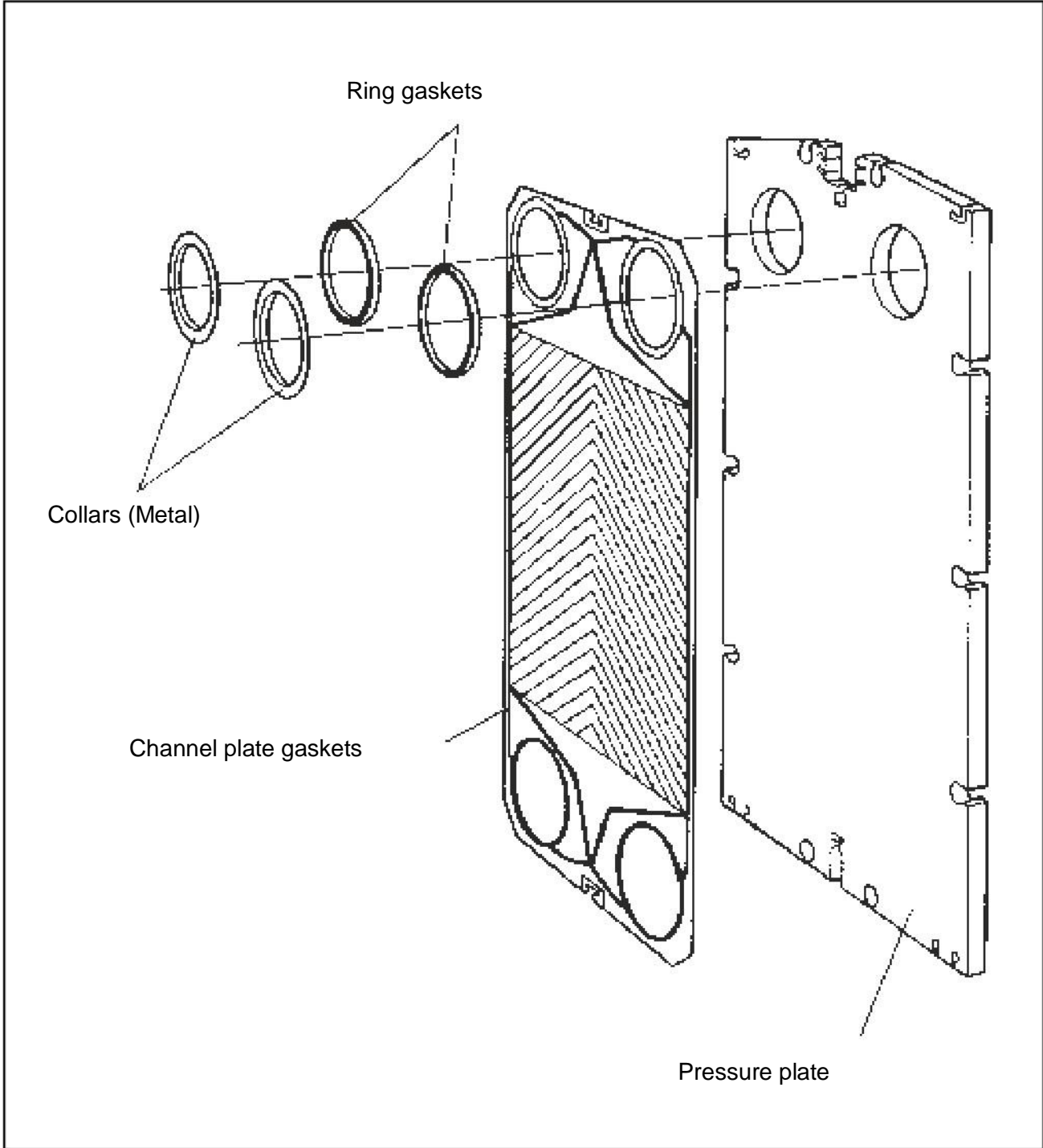

DIAGONAL FLOW UNITS

4B

NON MACHINED PRESSURE PLATE

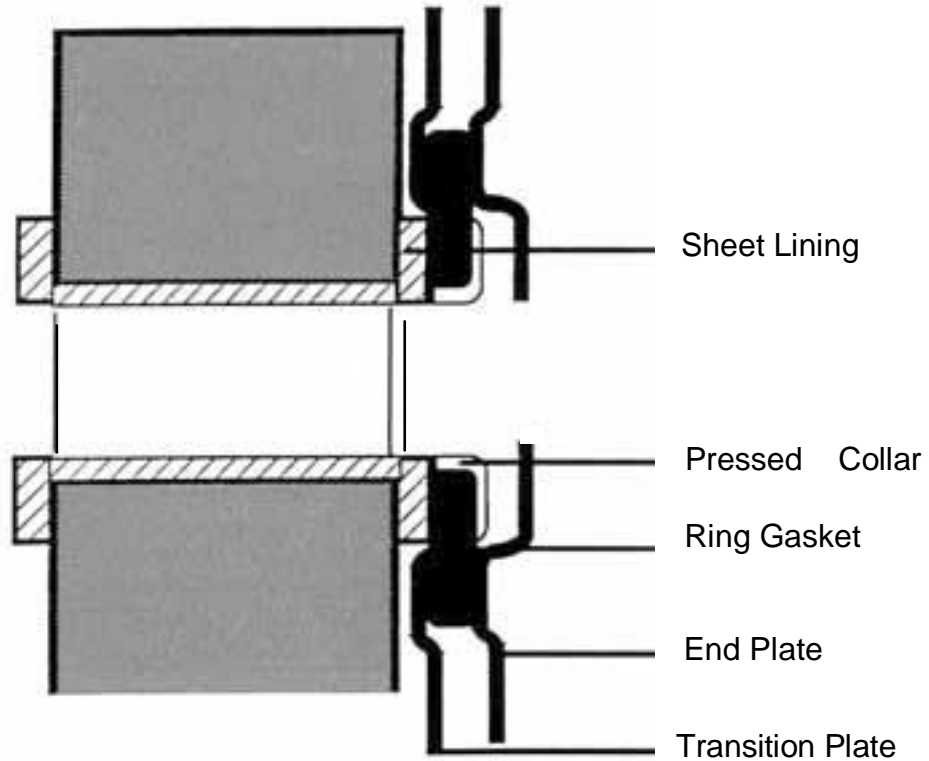

MACHINED PRESSURE PLATE (AX30, AM20 AND OBSOLETE FRAMES)

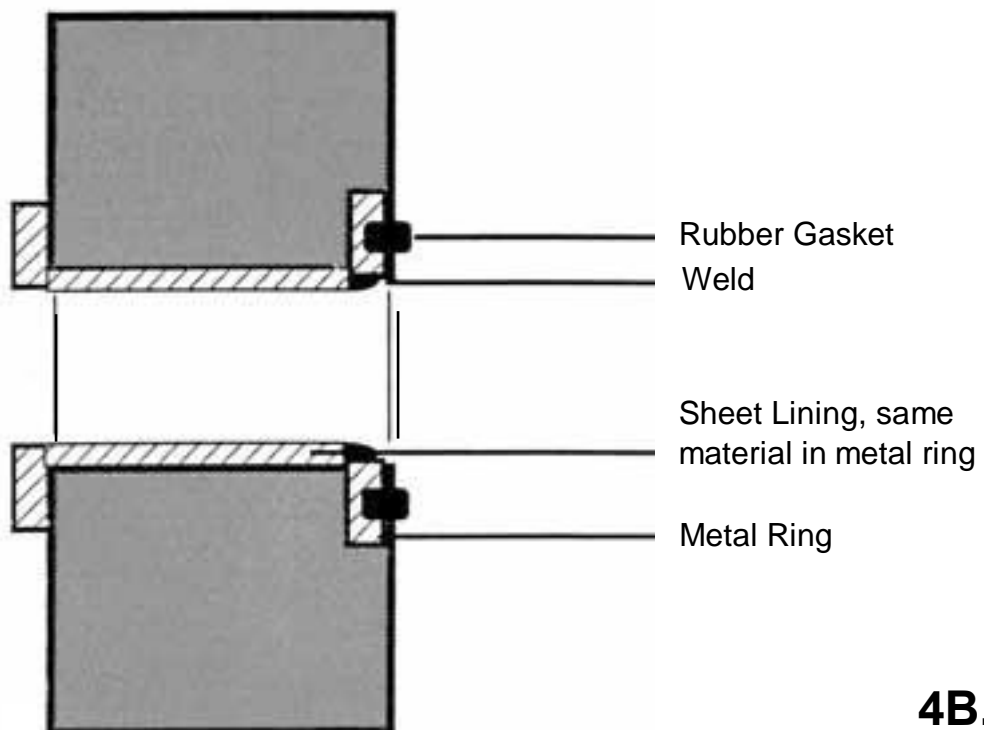

5

Operation

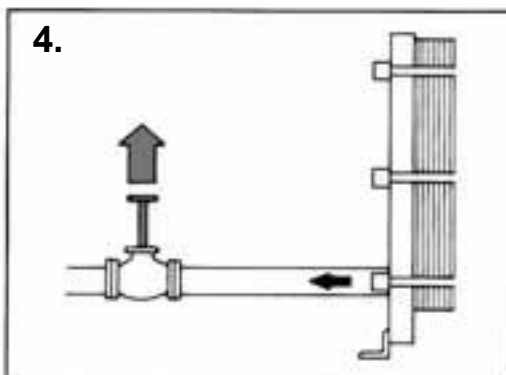
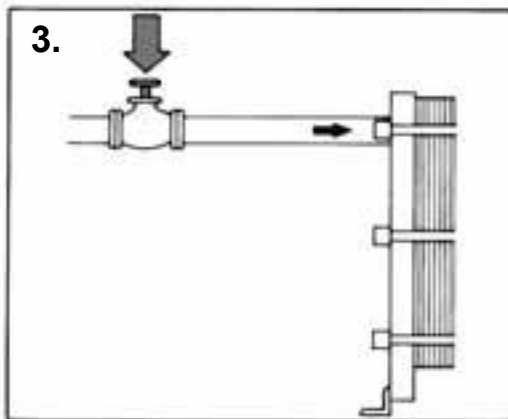
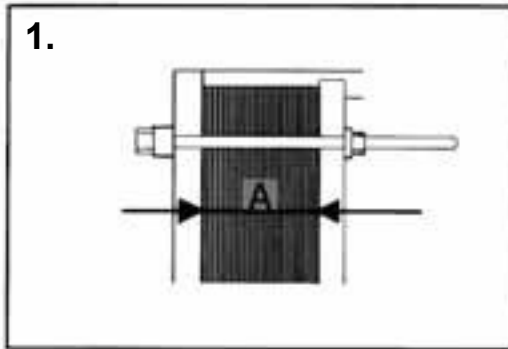

START UP

1. BEFORE STARTING UP FOR THE FIRST TIME OR AFTER A LONG TIME IN STORAGE: MAKE SURE THAT THE PLATE PACK IS COMPRESSED TO THE CORRECT MEASUREMENT A! Check with the Drawing or Nameplate, which is provided with each heat exchanger.

It is very important that the system to which the heat exchanger is connected, is protected against sudden and extreme variations of temperature and pressure. This is not only for the heat exchanger but also for the pipe system itself and every piece of equipment included in it.

This should be kept in mind whenever a maneuver is to be carried out, including starting up of the pumps in the system.

2. Before starting any pump, check whether instructions exist, telling you which pump should be started first.
3. Check that the valve between the pump and the equipment, controlling the flow rate of the system which you are about to start up is closed.
4. Check that the valve at the exit, if there is one, is fully open.

5.1

Operation

5

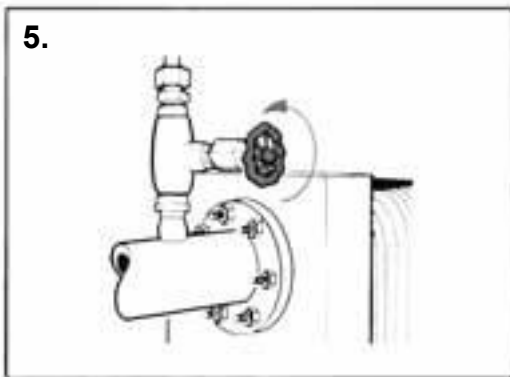

5. Open the vent.



6. Start the Pump.

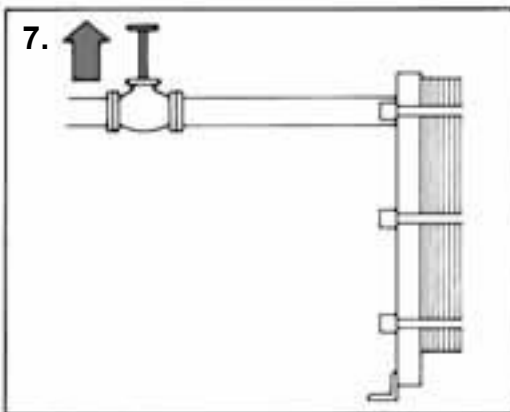

7. Open the valve slowly.

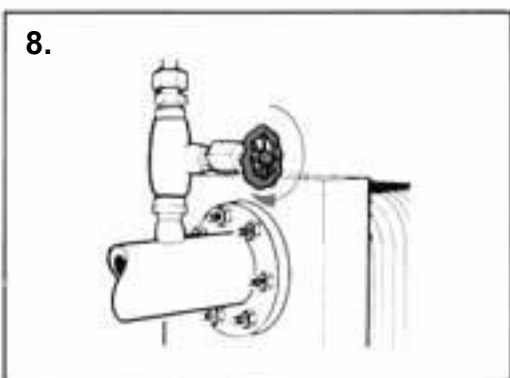

8. When all air is out, close the vent.

9. Repeat the procedure for the other media.

5

Operation

UNIT IN OPERATION

Any adjustment of the flowrates required to maintain correct temperatures or pressure drops should be made slowly, in order to prevent shocks to the system.

Problems in keeping up the performance of the heat exchanger may be caused by a change in some of the temperature conditions, the heat load or by fouling.

As long as the PHE is operating to satisfaction, it should be left without any interference.

SHUT-DOWN

If the heat exchanger is going to be shut down - or if for any reason the pumps are to be stopped - the following procedure should be followed:

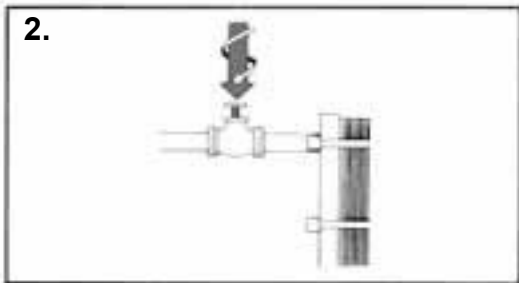

1. First establish whether instructions exist that specify which side should be stopped first.

2. SLOWLY CLOSE THE VALVE controlling the flow rate of the pump you are about to stop.

3. When the valve is closed, stop the pump.

4. Repeat the procedure for the other side.

5. Poor quality cooling water may be hazardous to metallic materials. Typical examples are corrosion of stainless steels and nickel alloys.

If for any reason the heat exchanger is shut down for a longer period (more than a number of days), it should be drained, and depending on the media processed, it is recommendable to rinse and dry it.

THE RISKS OF NOT COMPLYING WITH THE START-UP AND SHUT-DOWN PROCEDURES.

A liquid in motion in a pipe system represents a lot of energy, and it must be very carefully dealt with.

Particularly when the fluid is stopped it is imperative that this is done smoothly.

NOTE!

For this reason fast-closing valves should not be used unless the pipes of the system are very short.

Valves must be operated gradually. The longer the pipes and the higher the flow rate, the more important this becomes.

WATER HAMMER is the name given to a short duration pressure peak, traveling along the pipe as a wave at the speed of sound, and resulting from a sudden deceleration of the motion of the fluid in a closed system.

Thus, it is usually related to the shutting down of a system. However, when starting up a system with open valves and empty pipes, the fluid may burst into some obstacle, like a fine mesh strainer, a flow meter or a heat exchanger, causing a sudden reduction of the flow velocity - if not a complete halt, and so we may have the conditions of a Water Hammer.

In the worst case, the pressure surge caused by such a sudden stop of the motion of a fluid, can be several times the normal pressure of the system.

Therefore it is very important for the protection of the whole installation that start-ups and close-downs are carried out with great care.

6

Opening

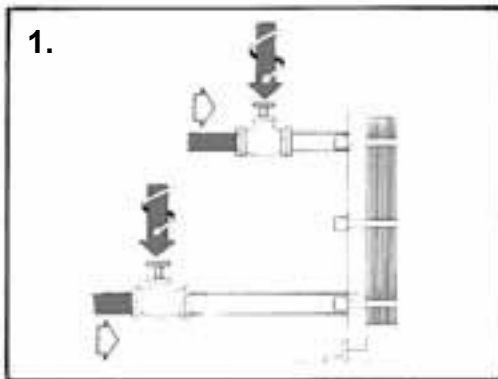

1. Slowly close the valves on the inlets. Shut off the inlet side, closing the highest pressure first.

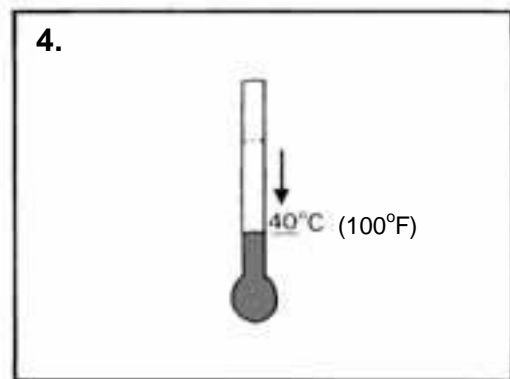

4. If the heat exchanger is hot, wait until it has cooled down to about 40°C (100°F).

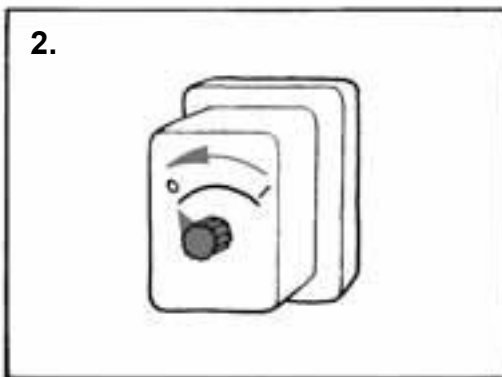

2. Switch off pumps.

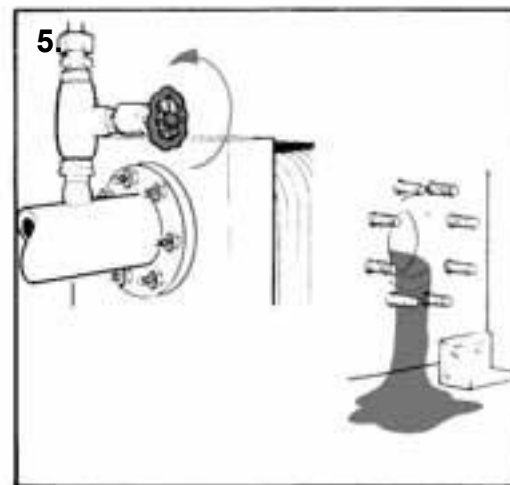

5. Drain

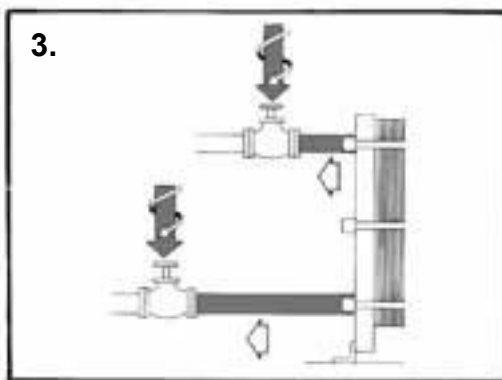

3. Close the valves on both outlets.

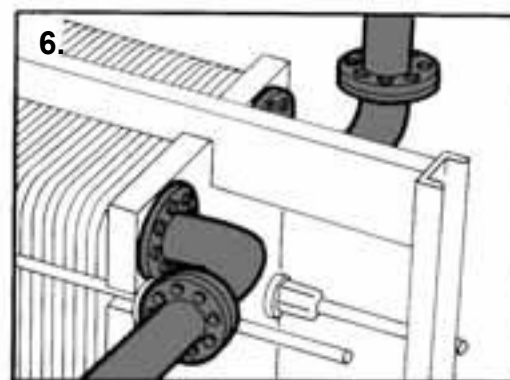

6. Dismantle any pipe bends connected to the pressure plate, so that it can be moved freely along the carrying bar.

6.1

Opening

6

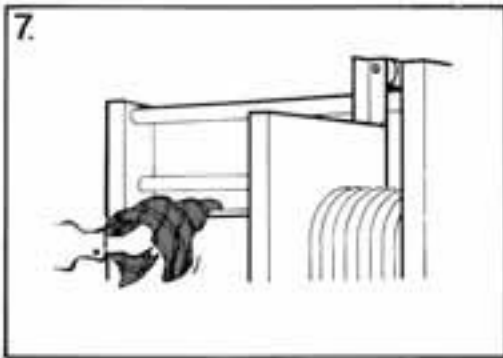

7. Inspect the sliding surfaces of the carrying bar and wipe clean

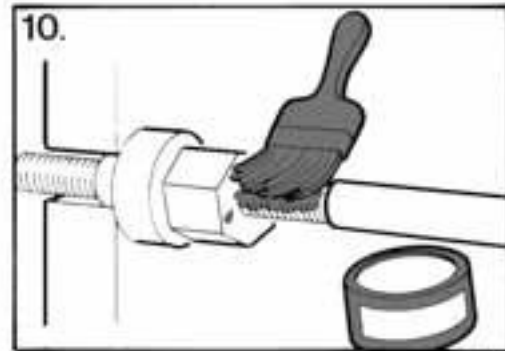

10. Lubricate the threads with a thin layer of grease, e.g LUBRIPLATE FGL-2 or equivalent.

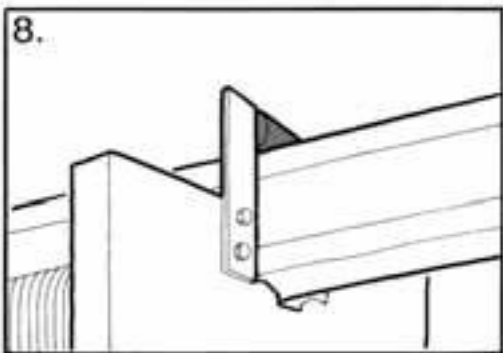

8. Inspect pressure plate roller.

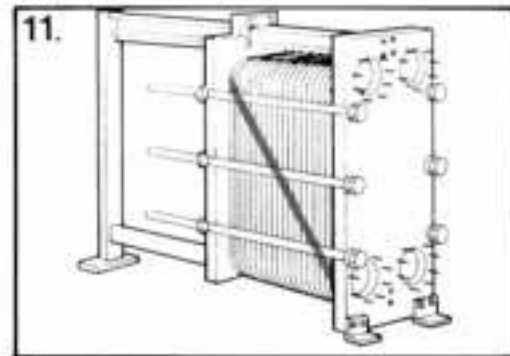

11. Mark the plate assembly on the outside by a diagonal line, or number the plates in sequence.

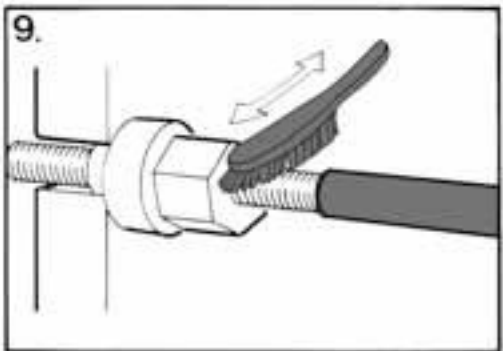

9. Pull back the plastic covers on the tightening bolts; brush the threads clean with a steel wire brush.

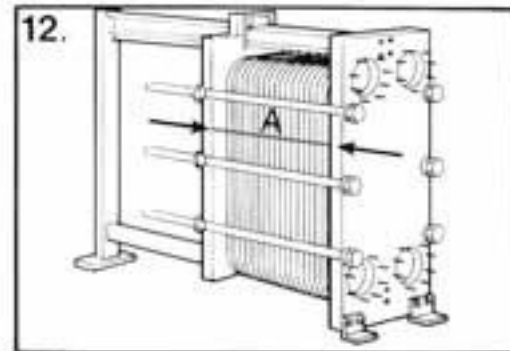

12. Measure and note the dimension A. Compare with code plate and PHE documentation for this same serial number.

6

Opening

	P2	A10B	TS6-M	AM10	M10B M10M
FG	X	X	X	X	
FM					X
FD			X		

⑬ (See page 6.5) ⑭

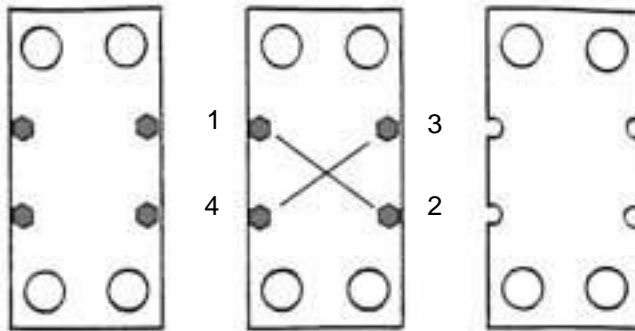

	V8	P3	V13 V20	V28	M10B M10M	M10BW M10DW	M20-M
E		X					
FD			X				
FG			X	X	X	X	
FM							X
VG	X						

⑬ (See page 6.5) ⑭

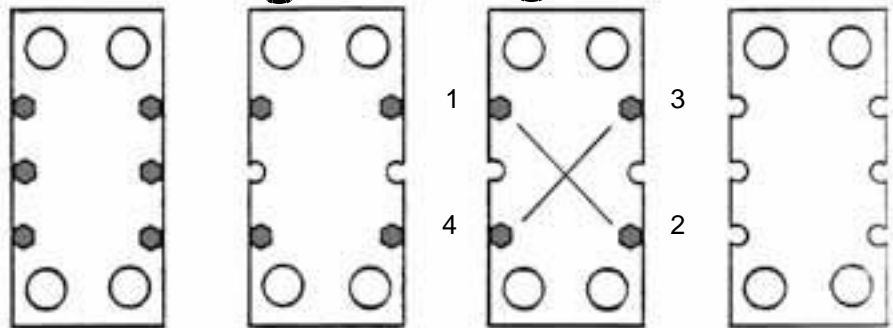

	M3	P2	P3	V28	V45
EH			X		
VG	X				
VLCH		X			
FG				X	X
FD				X	X

⑬ (See page 6.5) ⑭

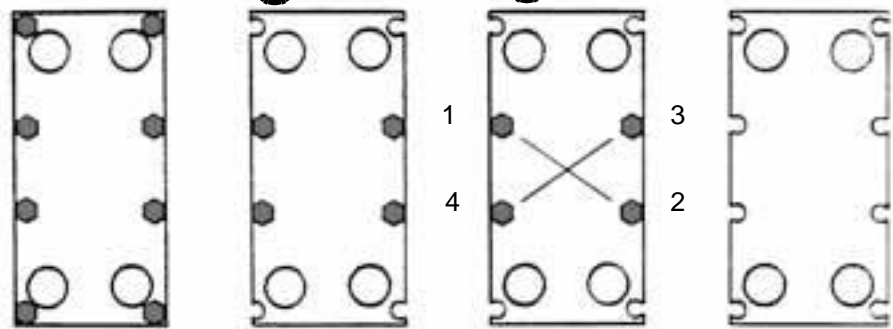

	MX25B	A15BWA	15B	TS20-M	AM20 AM20B AM20W AM20S AM20DW	M6 M6M	M15M
FG		X	X	X	X	X	X
FD		X	X				X
FL			X				
FM	X			X			X
FS				X			

⑬ (See page 6.5) ⑭

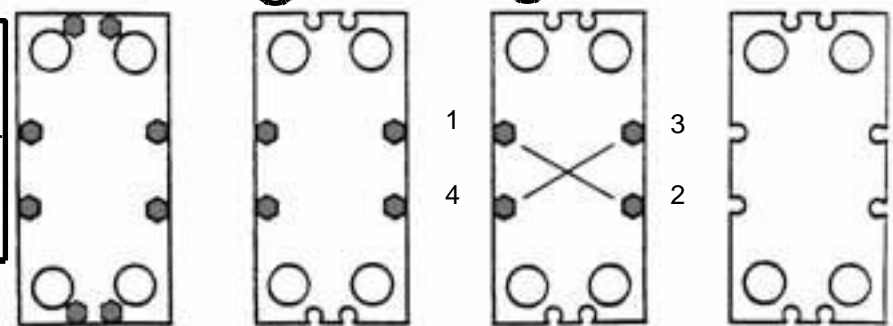

M6/M6-MFG & MX25-BFM ONLY HAS ONE BOLT TOP AND BOTTOM

Opening

	M20-M			
FG				

M20-MFG ONLY HAS ONE BOLT TOP AND BOTTOM

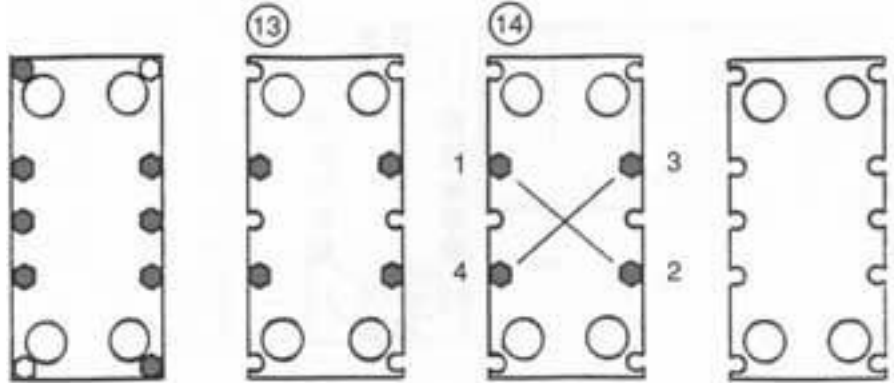

	M15B M15F	A20B	T200	M6 AK20 M6DW	M6M M30
FG		X	X		
FD				X	
FM					X
FS	X				

M6/M6-MFG ONLY HAS ONE BOLT TOP AND BOTTOM

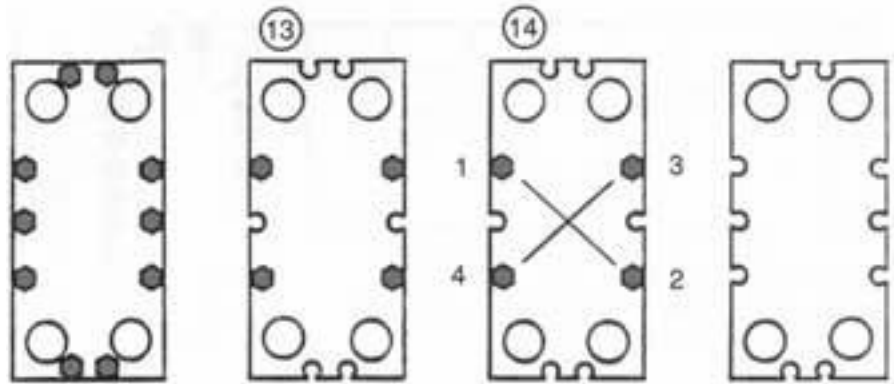

	M10B M10M	M10BW		
FD	X	X		

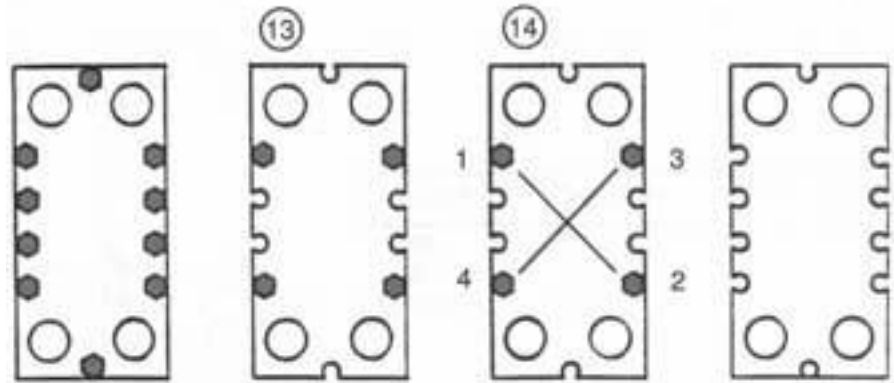

	A20B	AK20 T200	MX25B	V110
FD	X	X		
FL	X			
FG			X	X

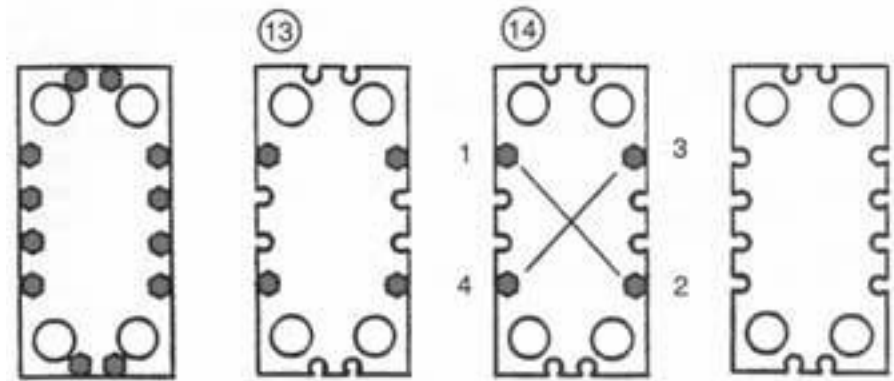

6

Opening

	AX30B AX30BW	V110		
FG FD	X	X		

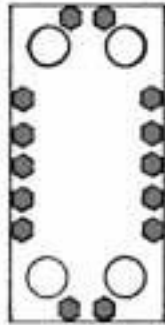

13

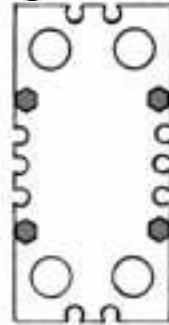

14

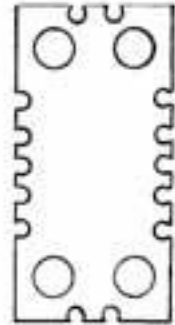
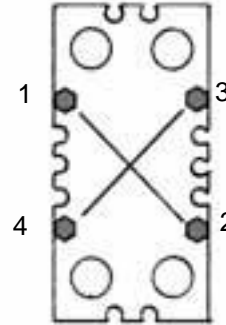

	AX30B AX30BW	A35 A45	AX35	M20M	M30	MX25B	V170 V280
FG FD HA FS	X	X	X	X	X X	X	X X

NOTE: M30-FD, MA30-FG/FD, MX25-BFS, V280-FG/FD and V170-FD have a twenty bolt or larger pattern, use this picture only as a guide. Start sequence numbers 5 and 6 at the fourth bolt down on both sides.

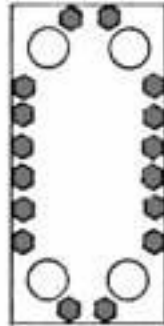

13

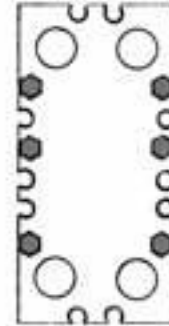

14

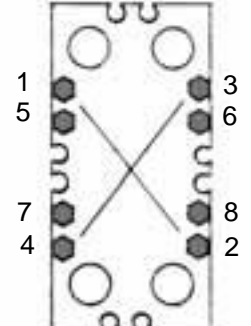

ORDER	BOLT NO.	TO DIM.
1	1-2-3-4-5-6	1.05A
2	1-2-3-4	1.10A
3	1-2 OR 3-4	OPENING

15

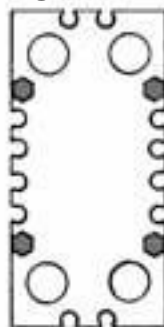

16

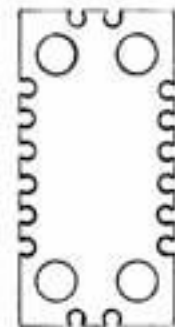
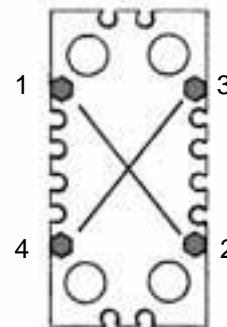

13 If bolts are fitted with bearing boxes loosen and remove them. If not fitted with bearing boxes, then follow the pictures above.

14 Loosen the remaining bolts, alternately and diagonally, to bring length to 1.05A.

15 Remove bolts 5 and 6 completely.

16 Continue opening, alternately and diagonally.

Note: Skewing of the Pressure Plate during opening must not exceed 10 mm (2 turns per bolts) across the width and 25 mm (5 turns per bolts) vertically.

6.5

Removal and insertion of plates

1.

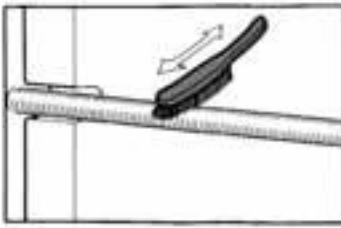

Brush the threads of the bolts clean, using a steel wire brush

2.

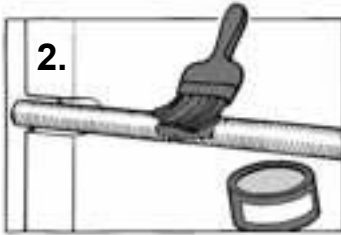

Lubricate the threads with a thin layer of grease, e.g. LUBRIPLATE FGL-2 or equivalent.

3.

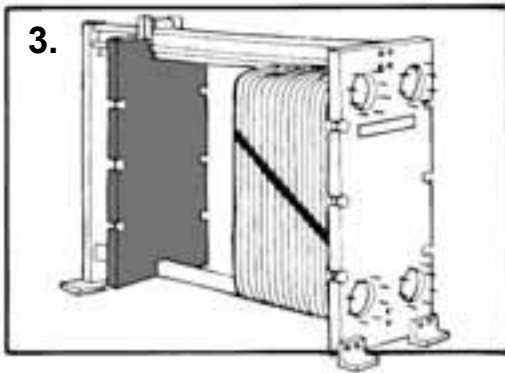

REMOVAL OF PLATES

3. Push the pressure plate against the support column.
4. Remove the plates. Stack them neatly on a skid or pallet for easy transporting.

4.

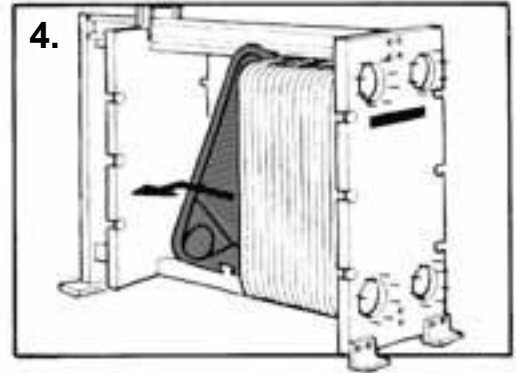

INSERTION OF PLATES

5.

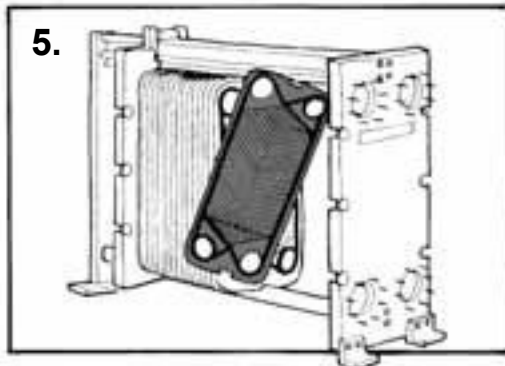

5. Hang the plates with their backs towards the pressure plate (the side without gasket).

6

Closing

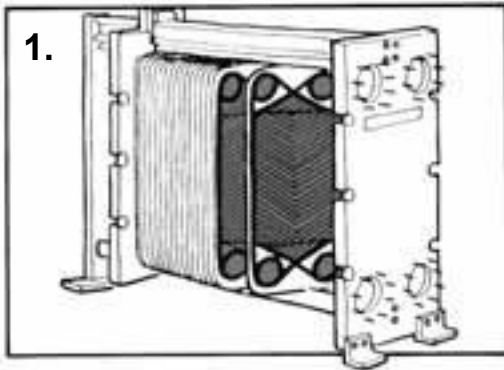

1. Check that all the sealing surfaces (i.e. surfaces in contact with the heat transfer medium) are clean.

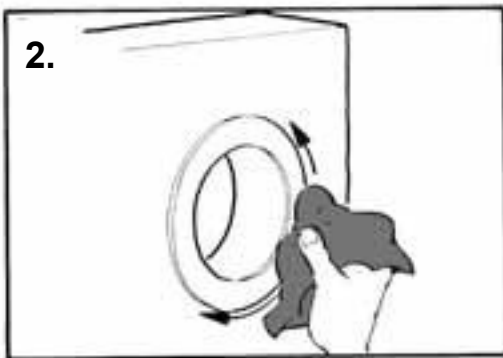

2. Check that the ring gaskets or liners, when fitted in connections, are in position and are in good condition.

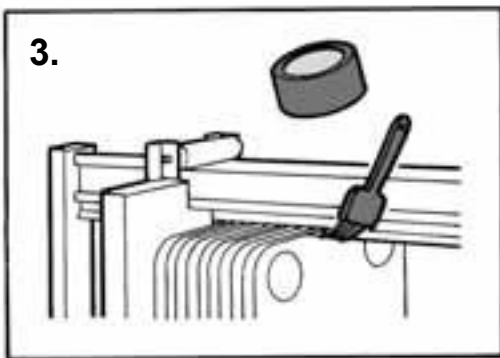

3. Clean and lubricate the sliding surfaces of the carrying bar.

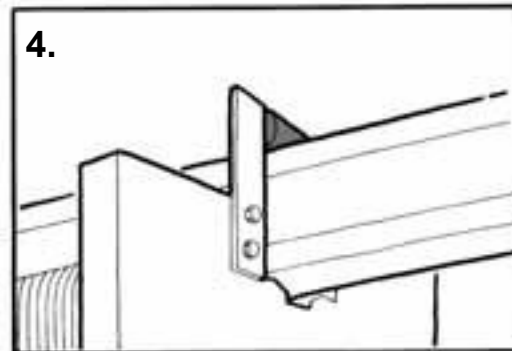

4. Inspect the pressure plate roller. Remove any debris from top surface of carrying bar.

5. Check against the drawing or flow sheet (provided with each heat exchanger) to make sure that the plates are hanging in the correct order.

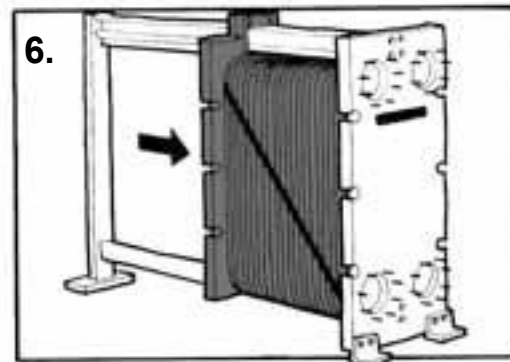

6. Press the plate assembly together.

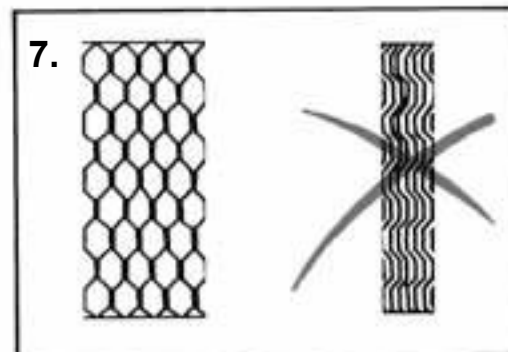

7. If the plates are correctly assembled, the edges form a "honeycomb" pattern.

If the plate pack has been marked on the outside (fig. 6) check this.

Closing

	P2	A10B	TS6-M	AM10	M10B M10M
FG	X	X	X	X	
FM					X
FD			X		

8 (See page 6.11) 11

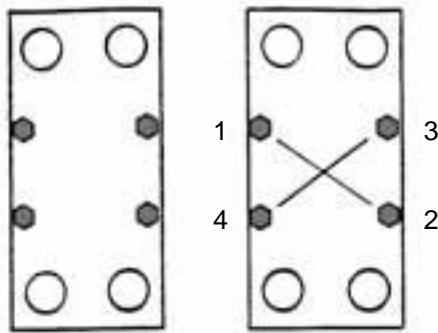

	V8	P3	V13 V20	V28	M10B M10M	M10BW M10DW	M20-M
E		X					
FD			X				
FG			X	X	X	X	
FM							X
VG	X						

8 (See page 6.11) 11

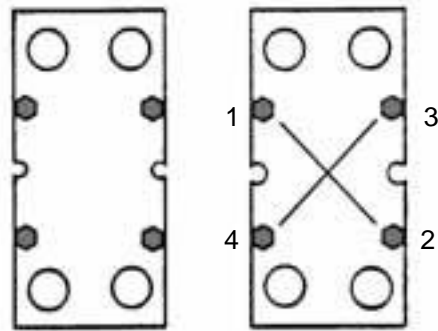

14 (See page 6.11)

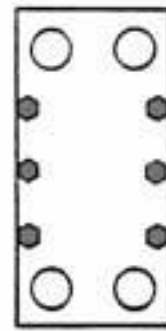

	M3	P2	P3	V28	V45
EH			X		
VG	X				
VLCH		X			
FG					X
FD				X	X

8 (See page 6.11) 11

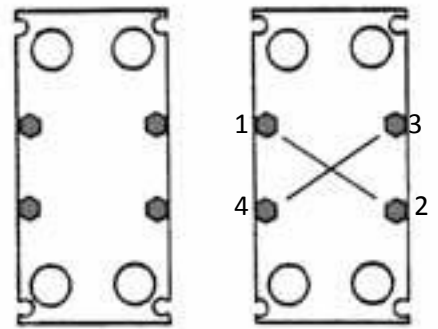

14 (See page 6.11)

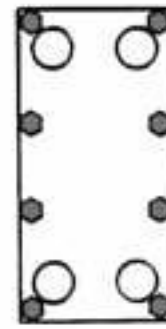

	MX25B	A15BW	A15B	TS20-M	AM20 AM20B AM20W AM20S AM20DW	M6 M6M	M15M
FG		X	X	X	X	X	X
FD		X	X				X
FL			X				
FM	X		X	X			X
FS				X			

M6/M6-MFG & MX25-BFM ONLY HAS ONE BOLT TOP AND BOTTOM

8

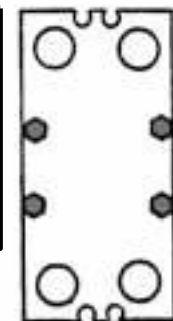

11

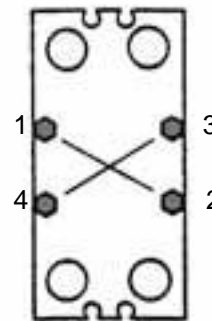

5

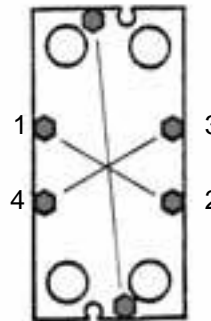

14 (See page 6.11)

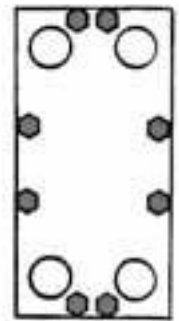

6

6

Closing

	M20-M			
FG				

M20-MFG ONLY HAS ONE BOLT TOP AND BOTTOM

8 (See page 6.11) 11

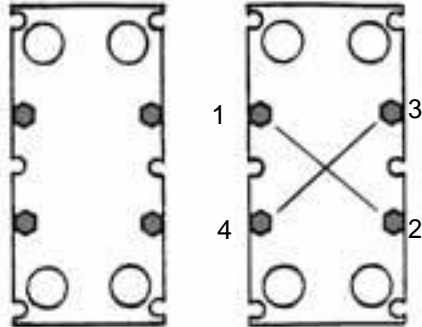

14 (See page 6.11)

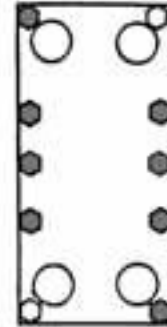

	M15B M15F	A20B	T200	M6 AK20 M6DW	M6M M30
FG		X	X		
FD				X	
FM					X
FS	X				

M6/M6-MFG ONLY HAS ONE BOLT TOP AND BOTTOM

8 (See page 6.11) 11

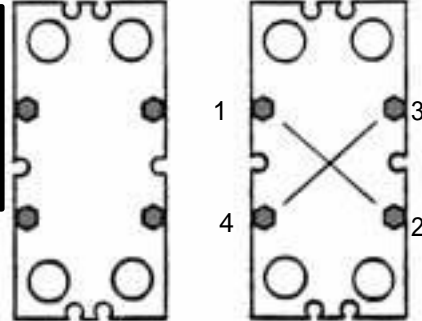

14 (See page 6.11)

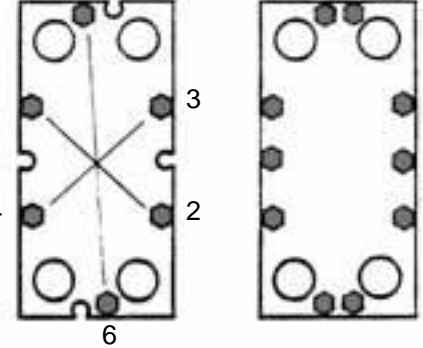

	M10B M10M	M10BW		
FD	X	X		

8 (See page 6.11) 11

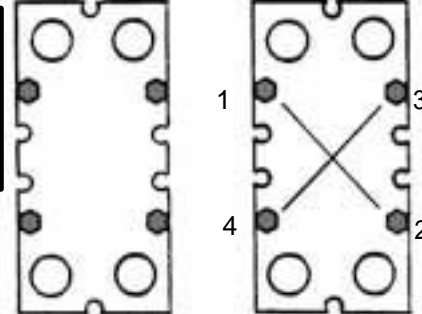

14 (See page 6.11)

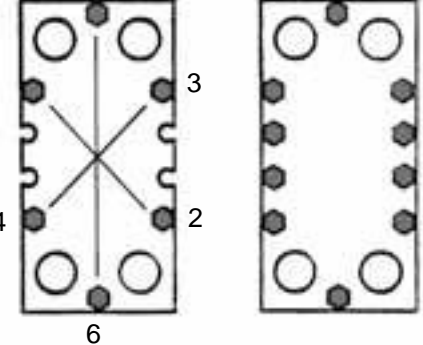

	A20B	AK20 T200	MX25B	V110
FD	X	X		
FL	X			
FG			X	X

8 (See page 6.11) 11

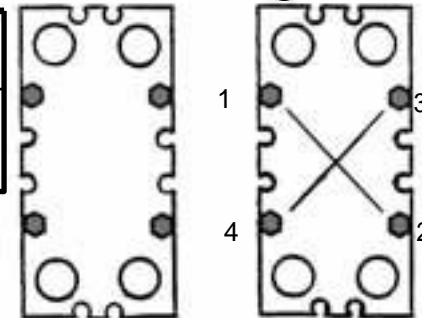

14 (See page 6.11)

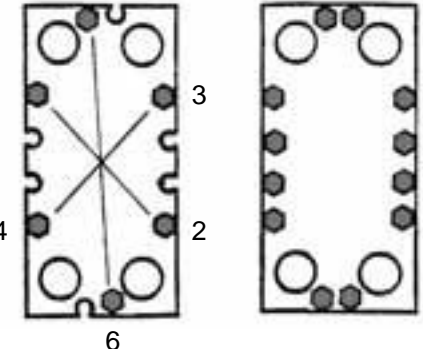

Closing

6

	AX30B AX30BW	V110		
FG	X			
FD		X		

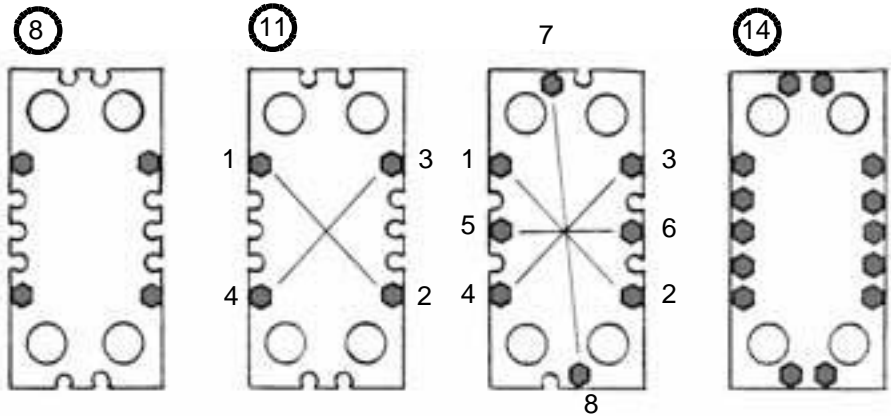

	AX30B AX30BW	A35 A45	AX35	M20M	M30	MX25B	V170 V280
FG	X		X		X		X
FD				X	X	X	X
HA		X					
FS						X	

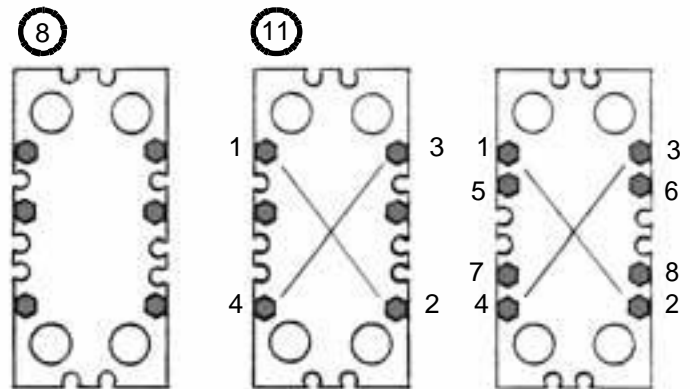

NOTE: M30-FD, MA30-FG/FD, MX25-BFS, V280-FG/FD and V170-FD have a twenty bolt or larger pattern, use this picture only as a guide. Start sequence numbers 5 and 6 at the fourth bolt down on both sides.

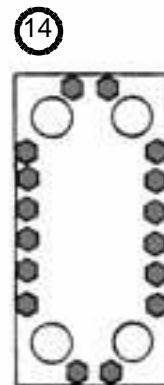

ORDER	BOLT NO.	TO DIM.
1	1-2-3-4-5-6	1.05A
2	1-2-3-4	1.10A
3	1-2 OR 3-4	OPENING

Note: See next page for closing instructions for all the models

6

Closing

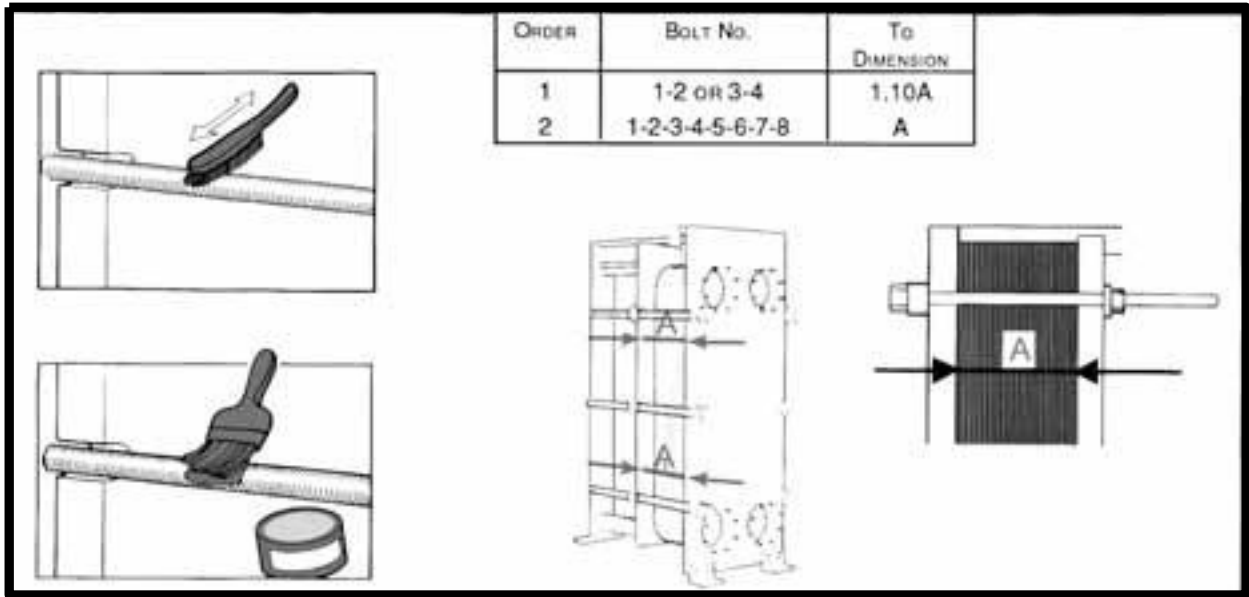

8. Place all the bolts that are fitted with bearing boxes in position. If not fitted with bearing boxes then follow the pictures for your specific model.
9. Brush the threads of the bolts clean, using a steel wire brush.
10. Lubricate the threads with a thin layer of grease, e.g. LUBRIPLATE FGL-2 or equivalent.
11. Tightening is carried out alternately and diagonally, as shown on the figure above.
12. Check the dimension A during tightening at the positions of the bolts that are being used. Skewing of the pressure plate during tightening must not exceed 10mm (2 turns per bolt) across the width and 25 mm (5 turns per bolt) vertically.
13. Nominal plate pack length A can be exceeded in exceptional cases, the tightening can be stopped at the following dimensions

Plate pack length/plat	Plate pack length
> 4 mm	A + 1%
> 3mm, < 4mm	A + 1.5%

14. Place the other bolts in position.
 - Inspect the washers.
 - When fully tightened, the bolts should all be equally tensioned.
 - The difference between the plate pack lengths measured at adjacent bolts should not exceed:
 - 2mm when dimension A is < 1000mm
 - 4mm when dimension A is > 1000mm
 - The plate pack length at all bolts must not differ by more than 1%
 - If the unit does not seal fully, it can be tightened to the dimension A-1%.

IF DIMENSION A IS NOT REACHED WITH APPLICATION OF THE ABOVE STEPS:

- Check the number of plates and dimension A.
- Check that all the nuts and bearing boxes are running freely. If not, clean and lubricate or replace.
- Fit all the bolts, and tighten alternately.

Chlorine as growth inhibitor

Chlorine, commonly used as growth inhibitor in cooling water systems, reduces the corrosion resistance of stainless steels (including Hastelloy, Incoloy, Inconel and SMO).

Chlorine weakens the protection layer of these steels making them more susceptible to corrosion attacks than they otherwise should be. It is a matter of time of exposure and concentration.

In every case where chlorination of non-titanium equipment cannot be avoided, ALFA LAVAL must be consulted.

Contact the following address:

ALFA LAVAL

Heat Transfer Center

5400 International Trade Drive

Richmond, VA 23231

Phone (804) 222-5300

Fax (804) 236-3276

NOTE! Titanium is not affected by chlorine.

7

Cleaning

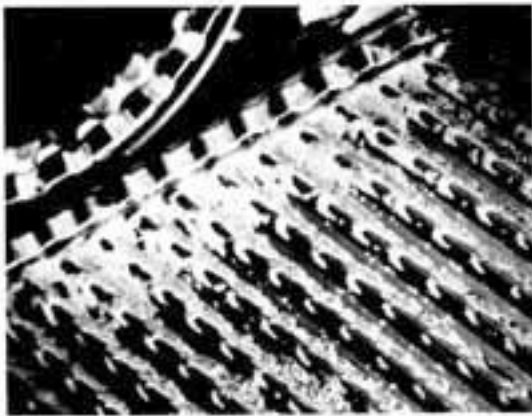

INCRUSTATION - SCALING

- Calcium carbonate
- Calcium sulphate
- Silicates

CLEANING

Mechanical cleaning after opening.

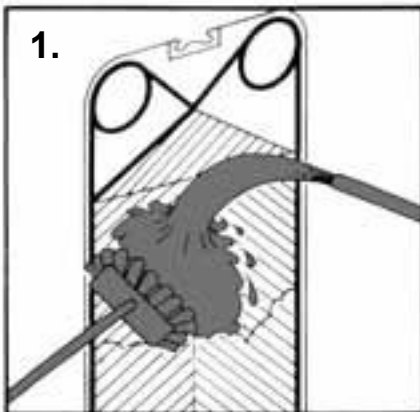

1. Soft brush and running water.
NOTE! Avoid gasket damage.

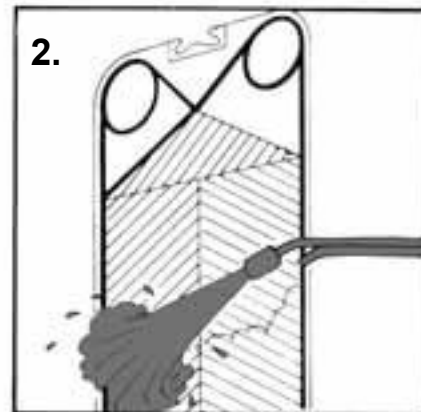

2. High pressure hose.

3. Chemical cleaning of opened unit by using:

- Nitric acid
- Sulfamic acid
- Citric Acid
- Phosphoric acid
- Complexing agents (EDTA, NTA)
- Sodium polyphosphates

Concentration max 4% by wt%
Temperature max 140° F

NOTE!

Under no circumstances should HYDROCHLORIC ACID be used with STAINLESS STEEL PLATES and under no circumstances should HYDROFLUORIC ACID be used with TITANIUM PLATES. Water of more than 300 ppm Chlorine may not be used for the preparation of cleaning solutions.

It is very important that carrying bars and support columns made of aluminum are protected against chemicals.

7.1

Cleaning

7

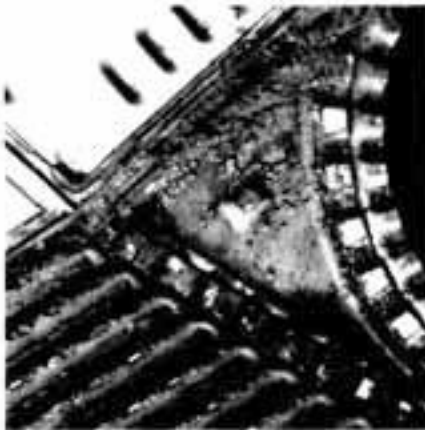

SEDIMENT

- Corrosion products
- Metal Oxides
- Silt
- Alumina
- Diatomic organisms and their excrement of various colors.

CLEANING

Mechanical cleaning after opening.

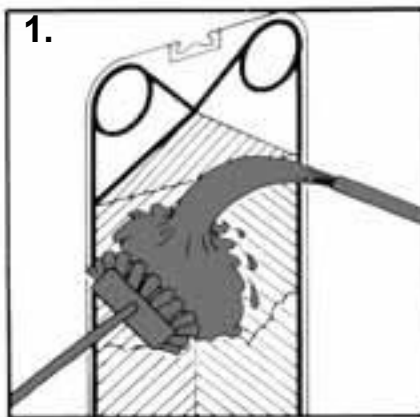

1. Soft brush and running water.
NOTE! Avoid gasket damage.
3. Chemical cleaning of opened unit by using:
 - Nitric acid
 - Sulfamic acid
 - Citric Acid
 - Phosphoric acid
 - Complexing agents (EDTA, NTA)
 - Sodium polyphosphates

Concentration max 4% by wt%
Temperature max 140° F

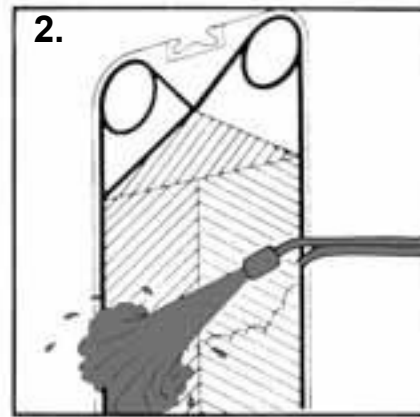

2. High pressure hose.
4. The addition of surfactants can improve cleaning effect.

NOTE!

Under no circumstances should HYDROCHLORIC ACID be used with STAINLESS STEEL PLATES and under no circumstances should HYDROFLUORIC ACID be used with TITANIUM PLATES. Water of more than 300 ppm Chlorine may not be used for the preparation of cleaning solutions.

It is very important that carrying bars and support columns made of aluminum are protected against chemicals.

7

Cleaning

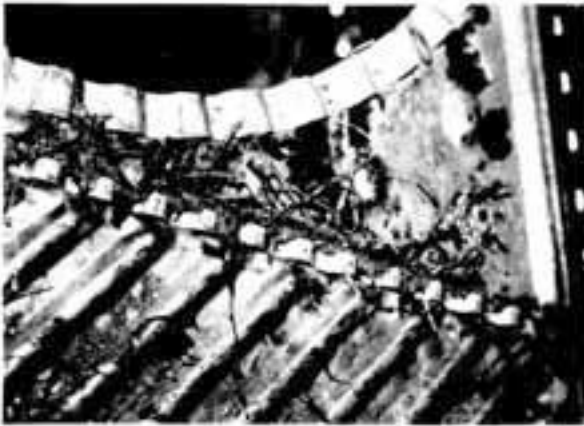

GROSS FOULING

- Seaweeds
- Wood chips/fibers
- Mussels
- Barnacles

CLEANING:

NOTE: BACKFLUSHING OF THE UNOPENED HEAT EXCHANGER CAN SOMETIMES BE SUFFICIENTLY EFFECTIVE.

Mechanical cleaning after opening.

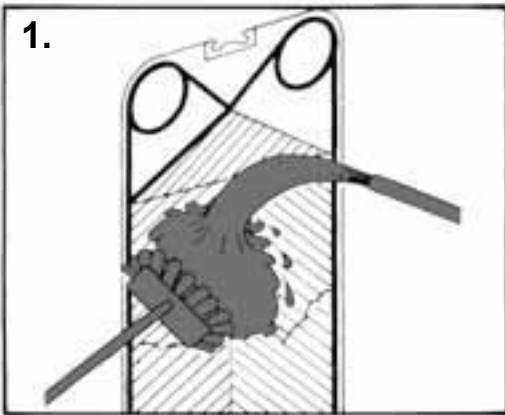

1. Soft brush and running water.
NOTE! Avoid gasket damage.

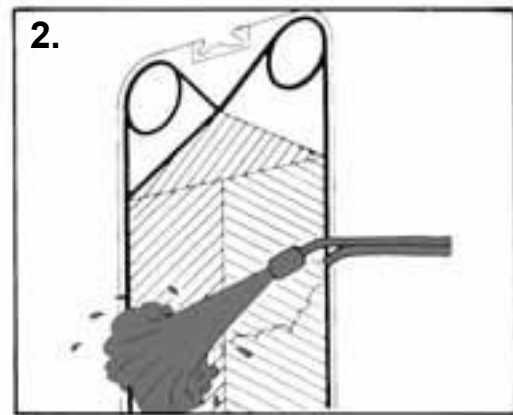

2. High pressure hose.

NOTE!

Under no circumstances should HYDROCHLORIC ACID be used with STAINLESS STEEL PLATES and under no circumstances should HYDROFLUORIC ACID be used with TITANIUM PLATES. Water of more than 300 ppm Chlorine may not be used for the preparation of cleaning solutions.

It is very important that carrying bars and support columns made of aluminum are protected against chemicals.

Cleaning

7



BIOLOGICAL GROWTH - SLIME

- Bacteria
- Nematodes
- Protozoa

CLEANING

Mechanical cleaning after opening.

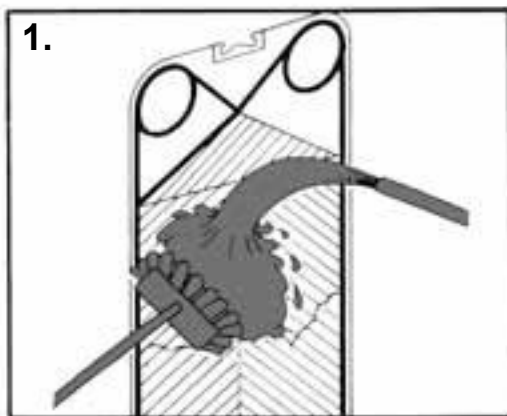

1. Soft brush and running water.
NOTE! Avoid gasket damage.

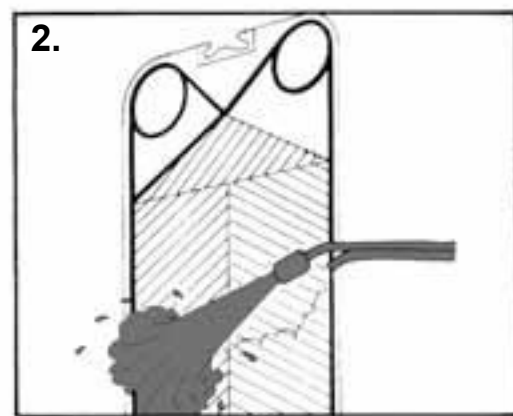

2. High pressure hose.

3. Chemical cleaning of opened unit by using:

- Nitric acid
- Sulfamic acid
- Citric Acid
- Phosphoric acid
- Complexing agents (EDTA, NTA)
- Sodium polyphosphates

Concentration max 4% by wt%
Temperature max 140° F

NOTE!

Under no circumstances should HYDROCHLORIC ACID be used with STAINLESS STEEL PLATES and under no circumstances should HYDROFLUORIC ACID be used with TITANIUM PLATES. Water of more than 300 ppm Chlorine may not be used for the preparation of cleaning solutions.

It is very important that carrying bars and support columns made of aluminum are protected against chemicals.

7

Cleaning

- Oil residues
- Asphalt
- Fats

CLEANING

Mechanical cleaning after opening.

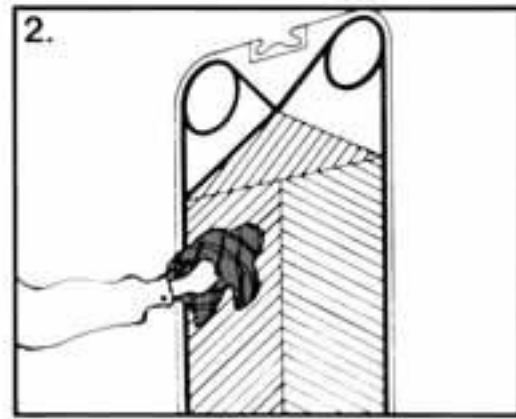
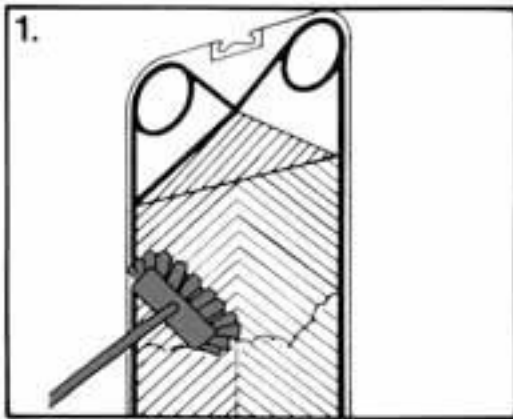

1. Hydrocarbon-based deposits may be removed by using a soft brush and a PARAFFINIC or NAPHTHA-BASED solvent (e.g. KEROSENE).

2. Dry with a cloth or rinse with water.

NOTE!
Gaskets in natural, butyl and EPDM rubber swell in these media.

Contact time should be limited to 0.5 hour.

THE FOLLOWING SOLVENTS SHOULD NOT BE USED

- Ketones (e.g. Acetone, Methylketone, Methylisobutylketone)
- Esters (e.g. Ethylacetate, Butylacetate)
- Halogenated hydrocarbons (e.g. Chlorothene, Carbon tetrachloride, Freons)
- Aromatics (e.g. Benzene, Toluene)

Regasketing

ALFA LAVAL has two types of glue for field repairs - GC11 and GC8 for repairs and exchange of gaskets in plates. A special glue is recommended for viton and silicone gaskets.

GC11

- A two-component, cold curing epoxy glue which gives a strong joint for higher temperatures.
- Future removal of gaskets usually requires heating or freezing of the joint.
- The shelf life is limited to approx. 1 year when stored at room temperature but can be prolonged when kept in a refrigerator.

GC8

- A single-component rubber-based solvent adhesive.
- Is normally used for repair work in an uncured condition.
- Can be used for operating temperatures below 200 F
- For operating temperatures above 200° F and oil coolers/heaters, the glued joints should be cured at 200° F for one hour.
- Future removal of the gasket can usually be carried out without heating of the cement joint.
- The storage life at room temperature is about two years. This period can be extended after checking the glue.

SEPARATE GLUING INSTRUCTIONS WILL BE DELIVERED TOGETHER WITH THE GLUE.

ALFA LAVAL RECONDITIONING SERVICE

In addition to supplying genuine gaskets for your plate heat exchangers, we are able to provide a "SPECIALIZED PLATE RECONDITIONING SERVICE" to quickly and efficiently meet your service requirements.

Our reconditioning service includes a liquid nitrogen debonding process with chemical cleaning, crack detection and regasketing using a special epoxy/phenolic resin adhesive.

This regasketing process requires special oven curing of the cement to ensure the strongest

possible bond strength between plate and gasket, similar to the process used during manufacture. This is one reason why our service is guaranteed.

In most cases our reconditioning service has proved more economical and much faster when compared with on-site regasketing methods.

For further details, please contact your local ALFA LAVAL REPRESENTATIVE.

(See Section 1)

7

Regasketing

The Clip-on gasket - a glue-free gasket system

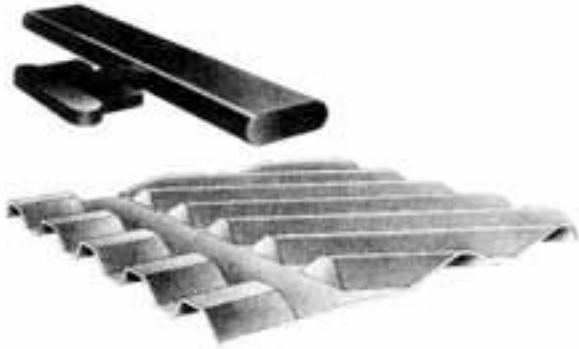

The Clip-on gasket is attached to the plate by two gasket prongs which slip under the edge of the plate to hold the gasket securely in alignment in the gasket groove.

The prongs are situated at regular intervals around the periphery of the plate.

When the plate heat exchanger is then assembled and tightened, the gasket provides a tight seal around the plate.



The Clip-on gasket in the gasket groove.

NOTE!

**Before closing of the equipment:
Check that the two gasket prongs
are in correct position.**

Regasketing of Snap-On Gaskets

7

THE PROCEDURES (2-7) ARE NOT NECESSARY FOR DOING A SMALL QUANTITY OF PLATES.
THESE PROCEDURES WILL INCREASE SPEED OF REGASKETING OF LARGE QUANTITIES OF PLATES.

PREPARATORY PROCEDURES



1. Pull the old gasket off the plate and clean the groove, if necessary.

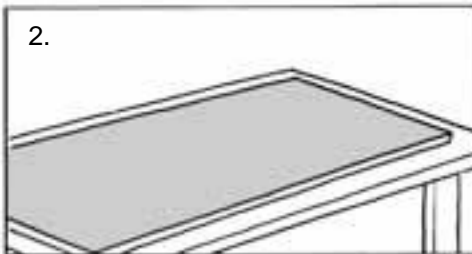

2. Place a flat sheet of plywood (somewhat larger than the PHE plate) on the table.

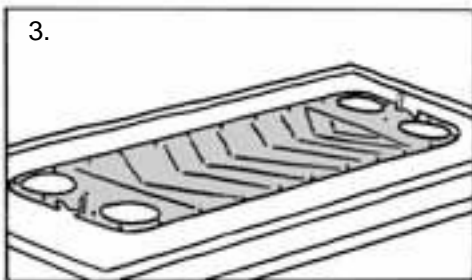

3. Place the PHE plate on the board with gasket groove upwards and fix firmly. Placing cylindrical pins in the plank at the carrying bar slots.

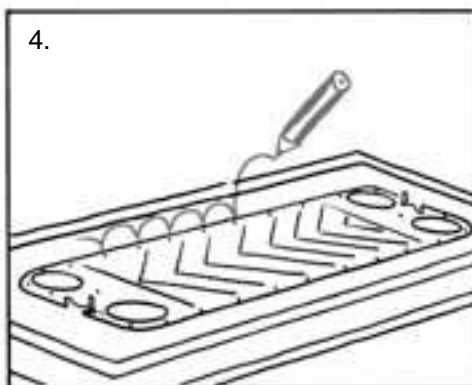

4. Make marks in the plank at all locations for gasket "snap-on".

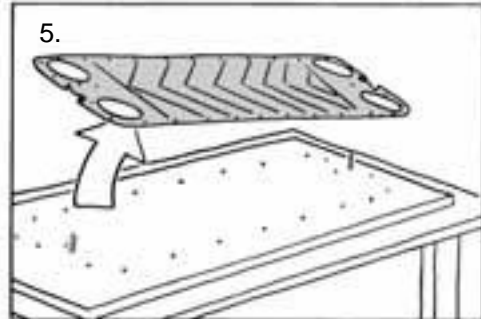

5. Remove the plate.

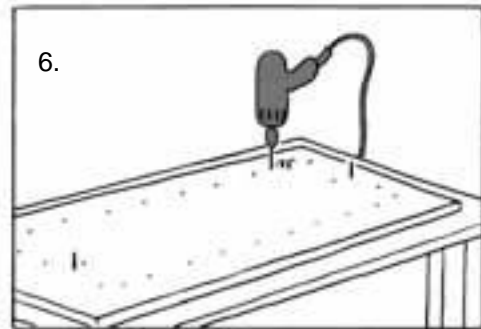

6. Drill holes approx. 7mm dia and 10 mm deep in the plank at the marked spots. The plank is now a practical tool for regasketing of larger numbers of plates.

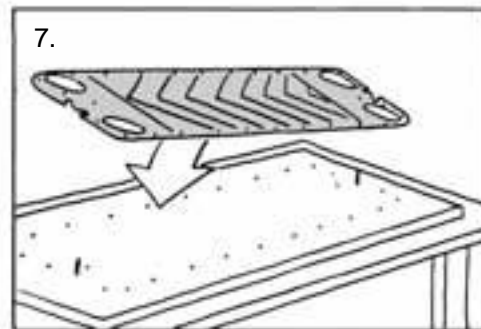

7. Replace PHE plate on the board in exactly the same location as at 3 above.

7 Regasketing of Snap-On Gaskets

FASTENING OF THE "SNAP-ON" GASKET

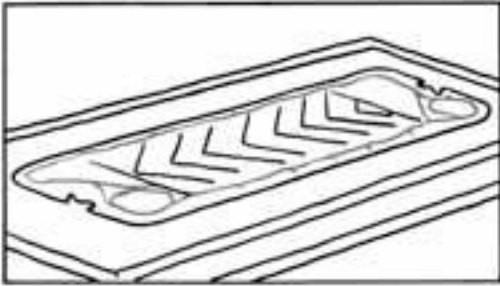

8. Place the gasket, with the "snap-on" projections downwards, in the gasket groove.

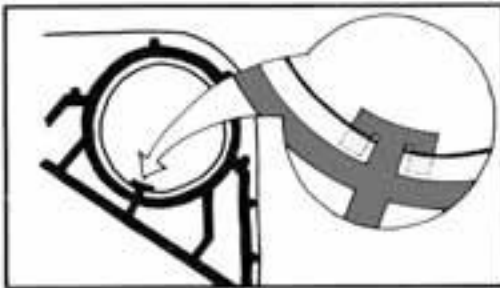

9. Place the ring gaskets in the groove and fix them with the T-flap.

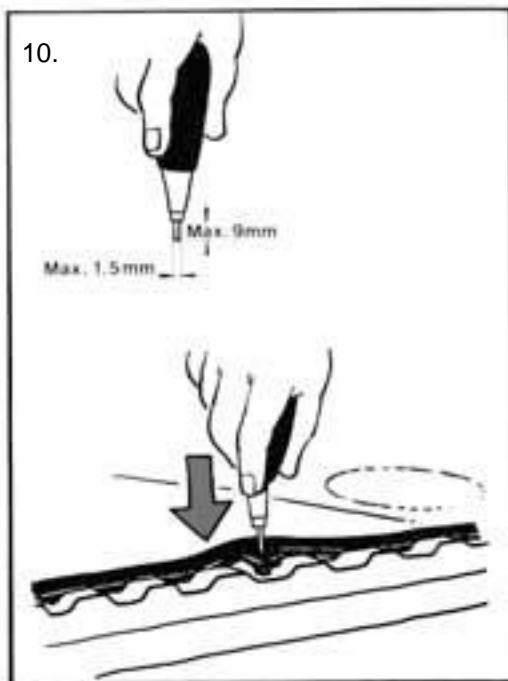

10. Insert the tool point into the recess in the projection.

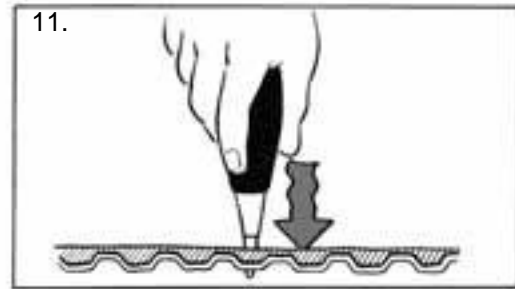

11. Push the projection through the hole in the plate.

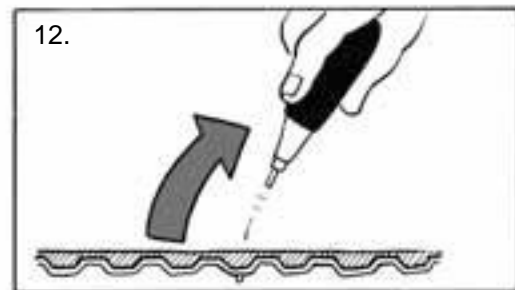

12. Remove the tool point, and the projection is now "snapped on".

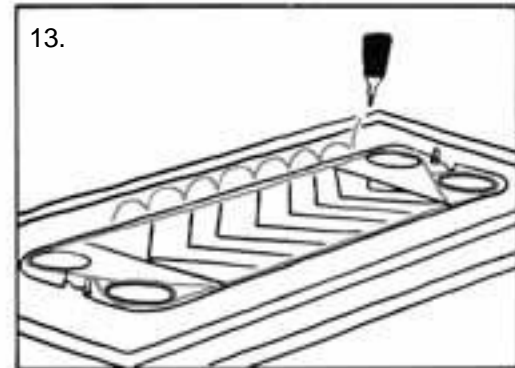

13. Repeat for all projections, and the gasket is "snapped on".

NOTE!
BEFORE CLOSING OF THE EQUIPMENT: CHECK THAT THE T-FLAPS ARE IN CORRECT POSITION.

PARALLEL FLOW UNITS

7

The End Plate II Gasket is formed by cutting (2) channel gaskets (as shown below) and gluing the gaskets to the first plate.

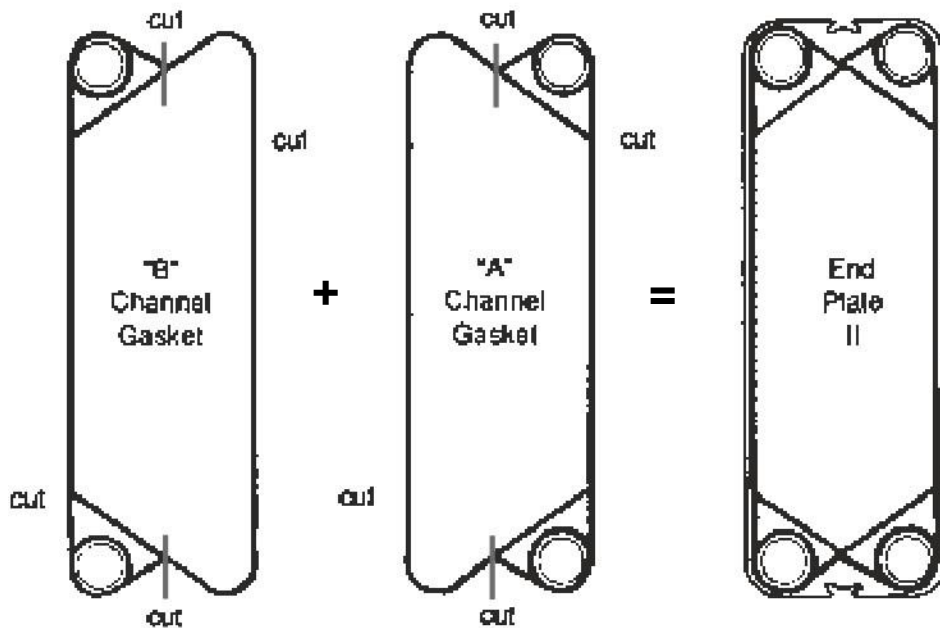

The (2) half channel gaskets should be glued to the end plate with GC-8 glue: or double sided tape (GC-1). The (4) port gasket areas are critical because these gaskets will be in contact with the process fluids.

7

DIAGONAL FLOW UNITS

The End Plate II Gasket is formed by cutting (2) channel gaskets (as shown below) and gluing the gaskets to the first plate.

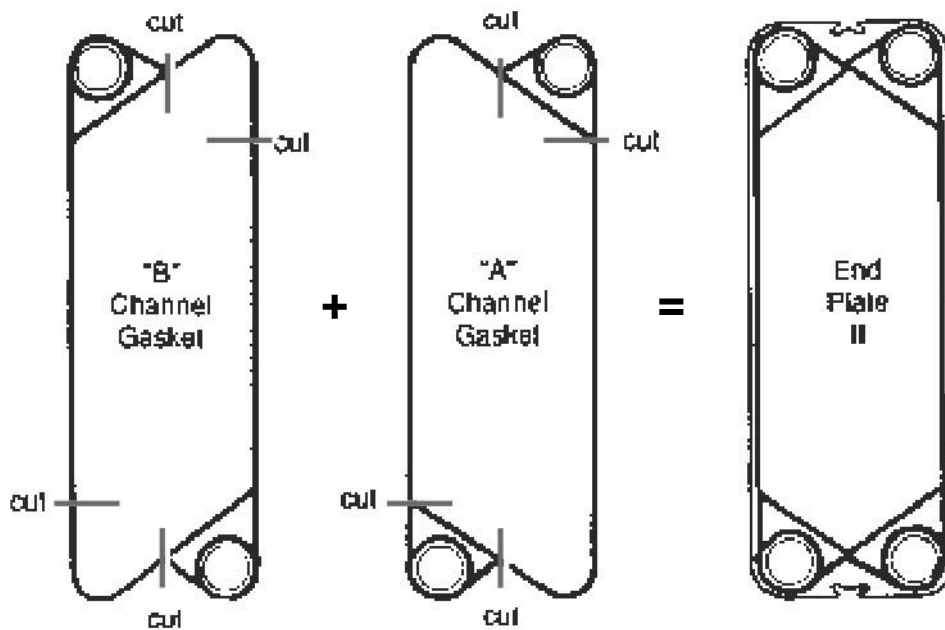

The (4) parts of the channel gaskets should be glued to the end plate with GC-8 glue: or double sided tape (GC-1). The (4) port gasket areas are critical because these gaskets will be in contact with the process fluids.

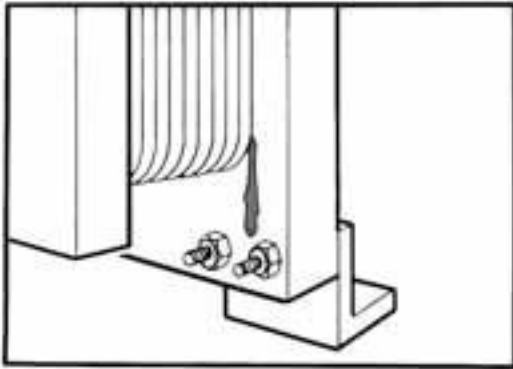

SYMPTOM

LEAKAGE between plates and frame.

ACTION

Mark with a felt tip or similar marker, mark the area where the leakage seems to be, and open the heat exchanger

1. Investigate the gasket condition of the end plate and the connection if applicable, look for dislocation, foreign objects, scars and other damage to the gasket surfaces.
2. Check the surface of the pressure plate for unevenness, foreign objects sticking to it, etc. that might spoil the joint between the gasket and the adjacent surface.
3. Check the plate itself for cracks or holes.

CORRECTIONS

1.
 - Relocate gasket.
 - remove foreign matter.
 - replace connection lining if applicable.
- Remove anything disturbing the joint between gasket and pressure plate surface.
- A perforated end plate must be replaced.

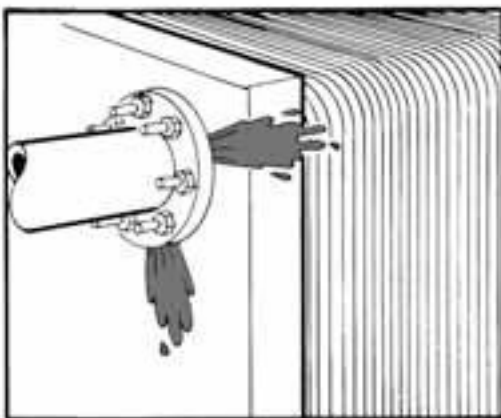

SYMPTOM

LEAKAGE between flange and frame.

ACTION

1. Disconnect the flange, and look for misalignment between flange and connection, dislocated or damaged gasket, foreign objects on the surface of the gasket or the flange.

CORRECTIONS

1.
 - Rearrange the pipe in order to eliminate stress and to correct alignment.
 - relocate gasket
 - replace damaged gasket
 - replace connection lining if applicable
 - remove foreign matter from flange and gasket
 - reassemble, taking care to avoid misalignment

8

Fault detection

NOTE: On a Plate Heat Exchanger specially designed for high temperature duties, extreme and sudden temperature drops may sometimes cause a temporary leakage. A typical example is a sudden shutting-off of the hot medium flow. The heat exchanger will normally seal again, as soon as the temperatures of the equipment have stabilized.

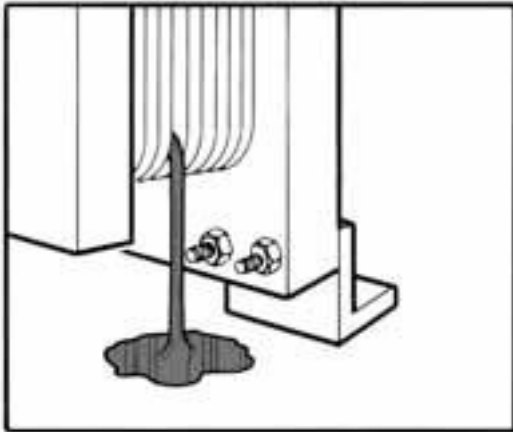

SYMPTOM

LEAKAGE between plates to the outside.

ACTION

Mark the leakage area with a felt tip marker on the two plates next to the leakage, check and note the length of the plate pack between inside frame plate and inside pressure plate, and then open the heat exchanger.

1. Check for loose, dislocated or damaged gasket.
2. Check for plate damage in the area, and also check plate pack length against the drawing to see if possible plate or gasket damage could be caused by overtightening of the plate pack, or if the leakage itself may simply be caused by insufficient tightening.
3. Check hanger recess at both plate ends for deformations, which could cause misalignment between the plates.
4. Make sure that the plates are hanging correctly as A-B-A (see SECTION 4A or 4B).
5. Check for perforation of the plate (corrosion).

CORRECTIONS

1.
 - Relocate gasket.
 - Re-cement loose gasket, if applicable.
 - Replace damaged gasket.
2. A damaged plate must in most cases be taken out for repair or replacement. If it is a regular plate with 4 holes: take the damaged plate and the 4-hole plate just in front or just behind it out of the plate pack. The heat exchanger can now be reassembled and put back in service PROVIDED THE PLATE PACK IS TIGHTENED TO A NEW MEASUREMENT, WHICH IS EQUAL TO THE ONE ON THE DRAWING, REDUCED BY TWO TIMES THE SPACE REQUIRED PER PLATE. CONTACT ALFA LAVAL FOR ASSISTANCE IN THE RECALCULATION IF NECESSARY.
The small reduction of the heat transfer area is normally of no importance, at least not for a short period of time.
 - Insufficient tightening must be corrected - see the drawing.
3. Damaged hanger recesses must be repaired if possible, or the plate replaced. For temporary arrangement with reduced number of plates - see paragraph 2 above.
4. Incorrect sequence of plates must be corrected (A-B-A-B-..). MAKE SURE THAT NO PLATE HAS BEEN DAMAGED, BEFORE REASSEMBLING THE PLATE PACK!
5. Perforated plates must be replaced. For temporary solution, see paragraph 2.

SYMPTOM

LEAKAGE between plates.

ACTION

CORRECTIONS

-
- | | |
|---|--|
| <ol style="list-style-type: none">1. Check that the piping is connected to the heat exchanger at correct locations.2. Open the lower connection on one side, raise pressure on the other side and by looking into the open connection try to detect any liquid from the pressurized side leaking in, and if so - approximately how far into the plate pack the leakage is located. If no leakage is detected, the reason for the mixing of media must be sought elsewhere. (see paragraph 5).3. If a leakage was detected, note the position of the leakage along the plate pack and then open the plate heat exchanger.4. Before starting on the plates themselves, check that the corner areas between the ring and the field gaskets are clear, that the leakage slots are open. This ensures that any leakage is out of the plate heat exchanger and is to atmosphere. Therefore no pressure can build up to force the media across the gasket sealing off the other liquid.5. If it has not been possible to locate the leakage as described in par. 2 above, it will be necessary to check each single plate for possible perforations, using any of the following methods:<ul style="list-style-type: none">• put a strong light behind the plate and watch for light coming through fine holes or cracks.• use a magnifying glass to check suspect area.• use a chemical penetrant, after having cleaned the plates well. | <ol style="list-style-type: none">1. Relocate piping to correct connections.4. All deposits or material which can block the free exit from the area must be removed. If the leak channels of the gasket have been destroyed, they must be reopened with a suitable tool, or the gasket replaced.5. Plates with holes must be replaced. The PHE may be temporarily operated with a reduced number of plates. See "LEAKAGE between plates to the outside". |
|---|--|

8

Fault detection

SYMPTOM

PRESSURE DROP PROBLEMS,
Pressure drop has increased

ACTION

CORRECTIONS

Check that all valves are open including non return valves.

Measure the pressure just before and just after the heat exchanger, and the flow rate. For viscous media a membrane manometer with a diameter of at least 30 millimeters should be used. Measure or estimate the flow rate if possible. A bucket and a watch showing seconds may be sufficient for small flow rates. For larger flow rates, some type of flowmeter is required. Compare the pressure drop observed with the one specified for the actual flow rate. (see plate print out)

1. If the pressure drop is higher than specified, the temperature program should also be checked:
 - 1.1 If the thermometer readings correspond to those specified, the heat transfer surface is probably clean enough, but the inlet to the heat exchanger may be clogged by some objects.
 - 1.2 If the thermometer readings are NOT corresponding to those specified, heat transfer is obviously dropping below specifications, because of deposits on the heat transfer surface, which at the same time also increase the pressure drop, since the passage becomes narrower.
2. If the pressure drop corresponds to the specifications, there is no need for any action.
3. If the pressure drop is lower than specified, the pump capacity is too small or the observation is wrong.

1. See next paragraph.
 - 1.1 Open the PHE and take out whatever is clogging the passage, or use the back-flush system - if there is one - to rinse out the cloggings.
 - 1.2 If a "cleaning-in-place" system is available, follow the instruction and use it to wash out the deposits. If not, open the PHE and clean the plates.
2. See pump instruction manual.

SYMPTOM: HEAT TRANSFER PROBLEMS

The heat transfer capacity is dropping

ACTION

CORRECTIONS

Measure temperatures at inlet and outlets and also flow rates on both media, if possible. At least on one of the media, both temperatures and the flow rate must be measured. Check to see if the transferred amount of heat energy corresponds to the specifications.

If great precision is important, it will be necessary to use laboratory thermometers with an accuracy of 0.2 degrees Fahrenheit, and also to use the best equipment available for flow measurements.

If the heat transfer capacity of the equipment has dropped below specified values, the heat transfer surface must be cleaned. Either use the “cleaning-in-place” arrangement if provided or open the heat exchanger for visual inspection and manual cleaning.

NOTE: Contact the Alfa Laval Sales & Service Division for CIP recommendations (See Section 1).

9

Supplementary Parts

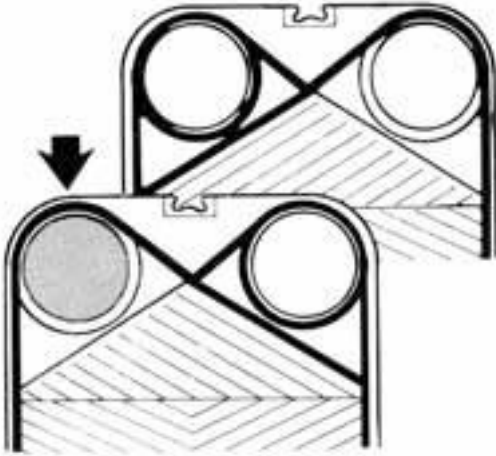

THE PARTITION PLATE - for special cases only.

If for instance, the thermal program requires that at least one of the media is to flow in more than one group through the plate package, there will be heat transfer plates with fewer than 4 holes.

To prevent the thin metal collapsing under the differential pressure, un-punched corners require extra support.

The extra support is provided by a partition plate - approximately the size of a channel plate - made of about 1/4" - 3/4" thick plate material with lined holes where a free passage is required.

The partition plate is suspended from the carrying bar. Where partition plates are required, in units with 8" ports or larger, there will be one at every turning point in a multi-grouped plate package.



Example only

9.1

